

István Gulyás

# THE DOCTRINE OF THE MODERN BOOKKEEPING

Elements of theory  
of the modern  $n$ -entry ( $n \geq 3$ ) special and  
general bookkeepings  
*between them*  
the  $n$ -entry property bookkeeping  
*and*  
their axiomatic system

(Death of the account theories)

2010

Publisher: István Gulyás; 1163-H. Budapest, Edit St. 15.

Author and translator: István Gulyás economist.

<http://www.ginprofessional.hu> ; <mailto:gulyas@ginprofessional.hu>

Budapest, 2010, second improved and advanced edition; published at the author own expense, firstly in 2009; in Hungary.



István Gulyás The axiomatic system of the  $N$ -fold ( $N \geq 3$ ) bookkeeping by scientific work is licensed under a Creative Commons Name it!-Do not sell It!-Do not change it! 2.0 UK: England and Wales License.

Based on a work at [www.ginprofessional.hu](http://www.ginprofessional.hu).

Permissions beyond the scope of this license may be available at [www.ginprofessional.hu](http://www.ginprofessional.hu).



István Gulyás  
Economist

The author in 2009

(Born: 17 October 1948)

The original title of this work in Hungarian language:

Gulyás István  
**MODERN KÖNYVVITELTAN**

***A modern  $n$ -szeres ( $n \geq 3$ ) vagyonskönyvvitel,***  
mint  
***az egyik speciális könyvvitel***  
***elméletének elemei***  
és  
***axiomatikus rendszere***

**(a számlaelméletek halála)**

ISBN 978-615-5050-04-6 online (epub) - 09/09/2010

“The things may show themselves surprisingly to other from new viewpoint such as they were ever when we met them. This one holds on the bookkeeping too.”

István Gulyás

## CONTENTS

<b>PREFACE OF THE EDITION 2 .....</b>	<b>11</b>
<b>1. THE ELEMENTS OF THE PROPERTY THEORY OF THE BOOKKEEPING .....</b>	<b>16</b>
<b>1.1 Principles.....</b>	<b>16</b>
1.11 Definitions.....	16
1.111 The concepts of theory of the general bookkeeping.....	16
1.112 The concepts of property theory of the special property bookkeeping.....	20
1.12 Axioms .....	25
1.121 The axioms of the property and other chronologic sets.....	25
1.122 Debt axioms .....	27
1.123 Economic and general event axioms .....	27
<b>1.2 The theorems of the property theory and their proofs .....</b>	<b>28</b>
<b>Attribute classifications and their features of the classes.....</b>	<b>28</b>
Theorem 1: If the economist has property in the $t$ th time point ( $t=1,2,\dots$ ), then in this property or rather in its any non-empty assets-aspect static property class belonging goods' quantity or monetary value (or other characteristic's measure) marker main or part sum is possible only positive number ( $T_1$ ).....	28
Theorem 2: If the economist has debt (other: liability or foreign capital) in the $t$ th time point ( $t=1,2,\dots$ ), then in its gross property's capital-aspect static middle class, whose name is still foreign capital class, or rather in its any non-empty middle or final class belonging part's quantity or monetary value (or other characteristic's measure) marker main or part sum is possible only positive number ( $T_2$ ). .....	30
Theorem 3 (Lemma): In the $t$ th time point ( $t=1,2,\dots$ ) the difference of the size of property of the economist and the in with it same measure expressed size of debt of the economist may be greater or less then zero, or equal to zero ( $T_3$ ).....	32
Theorem 4: The size of in the $t$ th time point ( $t=1,2,\dots$ ) given net property (alias: equity or eigen capital), as the non-negative gross property's capital-aspect relative base class' main sum, may be whatever sign number ( $T_4$ ). .....	32
Theorem 5: In the $t$ th time point ( $t=1,2,\dots$ ) of two static subclass, which ones spring the non-negative gross property with capital-aspect division, the main sum of the equity class may be any sign number, till the main sum of the foreign capital may be only non-negative number, in the sum of the two main sums are non-negative ( $T_5$ ). .....	33
Theorem 6: In the $t$ th time point ( $t=1,2,\dots$ ) to the static final class of the net property which named startup capital belongs part sum may be only positive number ( $T_6$ ). .....	33
Theorem 7: In the $t$ th time point ( $t=1,2,\dots$ ) to the static final class of the net property which named reserve capital belongs part sum may be only non-negative number ( $T_7$ ). .....	34
Corollary: From the theorem it is clear: if $C_R > 0$ then part sums of all non-empty subclasses of reserve capital class are also positive numbers. ....	35
Theorem 8: In the $t$ th time point ( $t=1,2,\dots$ ) to static cumulated gross result class of the net property, which named static cumulated yield class, belongs part sum, as in the $t$ th time point existing quantity or monetary value (or its other characteristic's measure) of the cumulated yield, we may express with only positive number ( $T_8$ ). .....	35
Corollary: From the theorem it is clear: if $Y_C > 0$ then part sums of all non-empty subclasses of cumulated yield class are also positive numbers. ....	35
Theorem 9: In the $t$ th time point ( $t=1,2,\dots$ ) to the subclass of static cumulated gross result class of the net property, which named static cumulated costs class, belongs part sum, as in the $t$ th time point existing quantity or monetary value (or its other characteristic's measure) of the cumulated costs, we may express with only negative number ( $T_9$ ). .....	35
Corollary: From the theorem 9 it is clear: if $C_C < 0$ then part sums of all non-empty subclasses of cumulated costs class are also negative numbers ( $T_9/C$ ).....	36
Theorem 10: If in the $t$ th time point ( $t=1,2,\dots$ ) the cumulated or rather the current period yield less then the with it in same measure given cumulated or rather current period costs' absolute value, then the in $t$ th time point existing cumulated or rather current period gross result's name is loss, if the yield is greater, then its name is profit, both are implicitly cumulated or rather current period ( $T_{10}$ ). .....	36
Corollary: From this theorem 10 it is already clear that in the $t$ th time point ( $t=1,2,\dots$ ) the cumulated or rather current period result $R$ may be any sign number ( $R \leq 0$ ) ( $T_{10}/C$ ). .....	37
Theorem 11: Let the gross property or its some part be classified in the $t$ th time point ( $t=1,2,\dots$ ) by assets- or capital-aspect. Additionally: the property changes, which ones result in this gross property or its part, let them be classified by time-aspect in the interval $(0;t]$ . Thus in the $t$ th time point to this static property class belonging main or rather part sum equal to the time classes of interval $(0;t]$ belonging with sum of part sums which may be only non-negative number, except the part sum of the equity class and result class which may be any sign number, just as the part sum of the costs class which may be only non-positive number ( $T_{11}$ ). .....	37
Corollary 1: From this theorem 11 it is already clear that the main or part sum of some class of any aspect static property classification may be any sign number if the elements of the class equal to with the elements of the equity or the result class. If however the static property classification is asset-like or within the capital-like it is debt-like, then the main or part sum of this static class may be only non-negative number. ....	38
Corollary 2: From this theorem 11 it is already clear that to the time classes $\mathcal{C}_{CH}(t)$ of the interval $(0;M]$ ( $t, M=1,2,\dots$ ) belonging from part sums $I(t)$ squarely follows to the $M$ th time-point belonging the value $P_M(\mathcal{C}_{ST})$ of the static property class $\mathcal{C}_{ST}(M)$ . However the reverse of this one is not true. But this relationship is true on the $P_M(\mathcal{C}_{ST})$ and its part sums of the static sub class too. ....	38

Theorem 12 (Lemma): If in the  $t=M$  time-point the main or part sum of the some static property class is non-negative (or non-positive), then in the interval  $(0;M]$ , in the class belonging property (property hiatus) resulting in to the property changes' first  $t$  ( $t=1,2,...,M$ ) time classes belonging sum of part sums is also such  $(T_{12}/L.)$ .....39

Corollary: If either part sum of some cumulated part sum property classification non-negative (or non-positive) then its other part sums are also such  $(T_{12}/C.)$ .....40

Theorem 13: If in  $t$ th time-point ( $t=1,2,...$ ) the main or part sum of some static property class is not zero then the static property class is non-empty  $(T_{13})$ .....40

Theorem 14: Let  $I(t)$  be part sum of  $t$ th time class of to the interval  $(0;M]$  belonging  $(t,M=1,2,...)$  property changes' classification. If in the interval  $(0;M]$  occurred property changes resulted in the  $M$ th time-point non-negative sized gross property or its in some static class extant part then, if  $1 \leq t \leq M$ , any part sum  $I(t)$  may be greater then zero or equal with zero. Till if  $2 \leq t \leq M$ , then any part sum  $I(t)$  may be less then zero, provided that absolute value of  $I(t)$  is not greater then the sum of the first  $t-1$  part sums  $(T_{14})$ .....40

Corollary: From this theorem 14 it is already clear that if in the interval  $(0;M]$  occurred property changes resulted in the  $M$ th time-point a some static property class with non-positive sized main or part sum then, if  $1 \leq t \leq M$ , any part sum  $I(t)$  of this dynamic property classification may be less then zero or equal to zero. Till if  $2 \leq t \leq M$ , then any part sum  $I(t)$  may be greater then zero, provided that value of  $I(t)$  is not greater then the absolute value of sum of the first  $t-1$  part sums  $(T_{14}/C.)$ .....42

Theorem 15: With the left property or its part related quantity/value of equity or part of equity with pass of time, some automatically, tends to minus infinite  $(T_{15})$ .....42

Corollary: The material position of the economist and all factors of one change with the lapse of time in case the quits of the economy too  $(T_{15}/C.)$ .....43

**The structural laws of the property and the property classification systems**.....43

Theorem 16:  $\sum_{x=1}^v S_x A_1 = \sum_{y=1}^z S_y A_2 = \dots = \sum_{\omega=1}^{\mu} S_{\omega} A_n \geq 0$ , that is: if we classify to the interval  $(0,t]$  belonging property

changes base class and/or to the  $t$ th time-point ( $t=1,2,...$ ) belonging balance class of it,  $n$  ways ( $n \geq 2$ ), namely by arbitrary but differing property aspect  $A_1, A_2, \dots, A_n$ , or if we complete the property classification system with a classification by aspect  $A_{n+1}$ , then the structures of classifications of this property classification system are differing, while the main sums of it, which ones expressed by same measure, are all equal  $(T_{16})$ .....43

Corollary 1:  $\sum_{i=1}^n A_i = C_E + C_F \geq 0$ , that is: if we classify set of balances (that is objects of the property) of to the interval

$(0,t]$  belonging gross property changes by two differing, that is: by assets and capital aspect it is classified, then this two structures of classifications system are also different, but the in same measure expressed two main sums are equal.  $(T_{16}/C_1)$ .....45

Corollary 2:  $\sum_{t=1}^M I(t) = \sum_{i=1}^n A_i = C_E + C_F \geq 0$ , that is: if set of to the interval  $(0,t]$  belonging gross property changes by time,

when the set of to the  $t$ th time-point belonging balances (that is objects of the property) by assets and capital, that is together: it is classified by three differing aspect, then the structures of classifications of this dynamic and static property classification system are different, but the in same measure expressed three main sums are equal.  $(T_{16}/C_2)$ .....45

Corollary 3:  $T^M = A^M = C^M = \dots = X^M \geq 0$ , that is: if the set of to the interval  $(0,M]$  belonging gross property changes by time, when the set of to the  $M$ th time-point belonging balances (that is objects of the property) by assets and capital plus other aspect, that is together: it is classified by  $N$  differing ( $N \geq 3$  and integer) aspect, then the structures of classifications of this dynamic and static property classification system are different, but the in same measure expressed main sums all are equal.  $(T_{16}/C_3)$ .....45

Theorem 17:  $\sum_{t=1}^M \sum_{i=1}^n A_i(t) = \sum_{t=1}^M C_E(t) + C_F(t) \geq 0$ , that is, to the  $t$ th time-points ( $t=1,2,...,M$ ) belonging the same unit and

A-C-aspect main sums of TA-TC-aspect dynamic property classification system of the gross property and their to  $M$ th time-point summarized sums are equal  $(T_{17})$ .....46

Corollary: The to the  $t$ th time-point ( $t=1,2,...,M$ ) same unit main sums of two arbitrary two different aspect dynamic property classifications of the gross property and to  $M$ th time-point summarized their sums are equal  $(T_{17}/C.)$ .....48

Theorem 18:  $\sum_{t=1}^M I(t) = \sum_{t=1}^M \sum_{i=1}^n J_i(t) = \sum_{t=1}^M V_S(t) + V_I(t) \geq 0$ , that is, to the  $t$ th time-points ( $t=1,2,...,M$ ) belonging the same

unit and A-C-aspect main sums of T-TA-TC-aspect dynamic property classification system of the gross property and their to  $M$ th time-point summarized sums are equal  $(T_{18})$ .....49

Corollary 1: The to some  $t$ th time-point ( $t=1,2,...,M$ ) belonging part sum of time-aspect property classification of the gross property equal with in the same unit expressed main sum of by any other but time and another aspect property classification which main sum is also to this  $t$ th time-point belongs  $(T_{18}/C_1)$ .....50

Corollary 2: To all  $t$ th time classes ( $t=1,2,...,M$ ) belonging part sums of any complex dynamic property classification system of the gross property and their sums are equal  $(T_{18}/C_1)$ .....50

**The relations of the economic events and the property classification systems**.....50

Theorem 19: Any and however many economist-specific economic event also occurs this fact does not affect the validity of T-A-C-aspect dynamic and static structural law of the gross property while this time to the economic event-coordinates corresponding to the final property class belonging part sums change to the character of the economic event(s) accordingly.....	50
Corollary 1: Absolute or relative main sum of any property classification is covariant (it changes same way) apropos of economic event occurring in point of increase or decrease of its part sum, while invariant in point of compensatory (an opposite sign but equal in size) changes of its two part sums.....	55
Corollary 2: Part sum of any property classification is invariant apropos of the economic event changing in point of its other part sum(s).....	55
Theorem 20: Any and however many economist-specific economic event also occurs this fact does not affect the validity of T-TA-TC-aspect dynamic structural law of the gross property while this time to the economic event-coordinates corresponding to the final property class belonging part sums change to the character of the economic event(s) accordingly.....	55
Corollary 1: The material position of the economist and its all factors apropos of economic-specific economic events in the time change.....	56
Corollary 2: The classifications of with the formula $T=A=C \geq 0$ represented property classification system independent each from the other regarding on the only structural property changes.....	56
Corollary 3: In the classifications of with the formula $T=A=C \geq 0$ represented property classification system, by the characteristic of the system, if the property increase or decrease then always 3 part sums change, one in the T and one in the A and one in the C-aspect classification, while if only the structure of some classification change then always 2 part sums change but only in T or only in A or only in F-aspect classification.....	56
Corollary 4: In the with formula $T=A=C=\dots=X \geq 0$ represented N aspect ( $N \geq 3$ and integer) property classification system, by the characteristic of the system, if the property increase or decrease then always N part sums change, but in a classification only one, while if only some classification structure changes when any classification is independent from the others, then always 2 part sums change in the either classification. If in the system there are yet additional non-independent K ( $1 \leq K \leq N-3$ and integer) property classification then at the most $2K+2$ part sums changes in all.....	56
Corollary 5: Aside from the time-aspect, in with the formula $A=C \geq 0$ represented property classification system, by the characteristic of the system, apropos of any economic event always only 2, to the A and/or the C property classification belonging, part sums change, if the property soever changes too.....	56
Corollary 6: The structural law of with the formula $T=A=C=\dots=X=0$ represented explicit N-fold ( $N \geq 3$ and integer) dynamic and static or with the formula $TA=TC=\dots=0$ represented implicit N-fold ( $N \geq 2$ ) dynamic property classification system will hold without the property and debt beginner economist in case ( $P_{GR}=0$ and $C_F=0$ ), just as if the economist has only debt ( $P_{GR}=0$ and $C_F=D > 0$ és $C_E=-D < 0$ and $C=C_E+C_F=0$ ), any and however many (but it is not impossible) economist-specific economic event occurs.....	57
<b>The law of the natural property classification and the natural property classes</b> .....	57
Corollárium 7: In the $t$ th time-points ( $t=1,2,\dots,M$ ) occurring economist-specific economic events $e_i(t)$ [ $i=1,2,\dots,n$ ] gradually and by natural chronology build up and in all $t$ th time-points clearly define the property classification system of the economist. In all $t$ th time-point of this natural process those part sums which ones correspond the character and coordinates of the events $e_i(t)$ change, that is, increase and/or decrease. This one happens then also if these changes are recorded and then also if they are not; and then also if coordinates of these events yet only can be inferable from the dates of time-point and name (description) of the economic events.....	57
<b>Complete and incomplete property classification systems</b> .....	57
Theorem 21: With the formula $T=A=C \geq 0$ represented explicit N-fold ( $N=3$ ) property classification system of in the interval $(0,M]$ changing gross property is complete system ( $T_{21}$ ).....	57
Corollary 1: With the formula $T=A=C=\dots=X \geq 0$ represented explicit N-fold ( $N \geq 3$ ) property classification system of the gross property is complete.....	59
Corollary 2: With the formula $TA=TC=\dots=TX \geq 0$ represented implicit N-fold ( $N \geq 2$ ) property classification system of the gross property is complete.....	59
Corollary 3: If the classification system of the gross property consists (possibly near other static property classifications) only from T, or A, or C, or A and C, or T and A, or T and C-aspect property classification, or it does not contain one of these nor, then such property classification system incomplete, although with the formula $A=C \geq 0$ represented property classification system is closed in point of the economist-specific economic events.....	59
Corollary 4: The time-, asset- and capital-aspect and by T-A-C-aspect property classification is immanent feature other attribute of the property classification.....	59
Corollary 5: The maximal number of the authoritative property-aspects is n, and $3 < n < X(t,A)$ , where X is natural number; its size is unknown and the value of the upper limit depend from the t time-point (t now is expressed in calendar year) and from the economic profile of the economist, just as from size and complexity of its economy, to which we may characterize the structure and main sum ( $A=\sum a_i$ ) of assets.....	59
Theorem 22: With the formula $T^M=A^M=C^M \geq 0$ or the $A^M=C^M \geq 0$ represented property classification system, which shows in cash-flow aspect from the gross property only the money property, is incomplete.....	59
Theorem 23: If the property classification system of the gross property is complete, is therein time, assets and capitals classification.....	61
Theorem 24: If the property classification system of the gross property is complete, then it is closed in point of the economist-specific economic events.....	61
Theorem 25: The N-pan ( $N \geq 2$ ) balance sheet of the gross property is complete system.....	62

Theorem 26: If a property classification system is complete, then it is an explicit N-fold ( $N \geq 3$ ) system, and at least a dynamic T, a static A and a static F property classification perform between its classifications, or it is the implicit N-fold ( $N \geq 2$ ) system, and at least a dynamic TA and a dynamic TC complex property classification perform between its classifications.....	62
Theorem 27: In the (0;M] interval the difference (or if the decrease is negative, algebraic sum) of same type measure data of the economic events, which occurred for increase and/or decrease of the gross property, is equal with the main sum of static classification of the gross property which belongs to the Mth time-point. ....	64
Theorem 28: With the formula $A=C \geq 0$ represented incomplete property classification system (classic balance sheet) of gross property is transformable so that let it be complete. ....	65
<b>The law of the material position</b> .....	66
Theorem 29: The $P_{GR}(M) = \sum_{t=1}^M \sum_{i=1}^n A_i(t) = \sum_{t=1}^M C_E(t) + D(t) \geq 0$ (where $P_{GR}(M) = \sum_{t=1}^M \sum_{i=1}^n A_i(t) \leq D(t) \geq 0$ and $C_E(t) \leq 0$ ; and $t=1,2,\dots,M; i=1,2,\dots,n$ ) formula represents the law of the material position. Mean of this law: The man and all other economist, from its birth to its death, its existence in all tth moment, (1) has gross property [ $P_{GR}(M) > 0$ ], but then has debt also [ $D(t) > 0$ ], (2) D(t) in the good case is significantly less, in bad case is greater then the gross property, (3) or it does have neither its property [ $P_{GR}(M) = 0$ ] its debt [ $D(t) = 0$ ] (this time it is pauper), (4) or its position worse at this one also because it has only debt [ $P_{GR}(t) = 0, D(t) > 0$ ] (this time it is pauper debtor). (5) And other case is not possible. (6) The material position of the economist and its all factors change in the time, the economist either economizes or leaves to itself its property, hence (7) its property, as its material position's either main factor, may investigate by N aspect ( $N \geq 3$ ), that is, at least by time, asset and capital-aspect ( $T_{29}$ ). ....	66
<b>2. THE BASE ELEMENTS OF THEORY OF THE PROPERTY BOOKKEEPING</b> .....	<b>67</b>
2.1 Principles.....	67
2.11 Definitions of the property bookkeeping.....	67
2.111 The concepts of the general bookkeeping.....	67
2.112 The concepts of the property bookkeeping.....	72
2.12 The axioms of the property bookkeeping.....	77
2.121 The documentary principle.....	77
2.122 The general bookkeeping principles of undefinable imperishableness of the truth-untruth dilemma.....	77
2.123 The principle of the inadequate controller automatons.....	78
2.124 The principle of economist-dependent of the abstract events.....	78
2.2 The theorems and their proofs.....	78
<b>Equivalence and isomorphism</b> .....	78
Theorem 1: The data-vectors of the economic event and the to it corresponding bookkeeping event are equivalent in point of their data which characterizes the change of material position of th economist (2./T <sub>1</sub> ). ....	78
Theorem 2: In the bookkeeping of the property the indirect image of the economic events just as apropos of the economic events nascent property and debt or rather its system of the classification makes an appearance in the form of bookkeeping events or rather by bookkeeping events (2./T <sub>2</sub> ). ....	79
Corollary 1: The image of the bookkeeping registration as image of factors and changes of the material position and this mapping's object in point of its character is necessarily equivalent (2./T <sub>2</sub> /C <sub>1</sub> ). ....	80
Corollary 2: The theorems and laws of the property theory hold in same form and with same content in the bookkeeping too (vice versa in generally this is not true) because in the property theory given system and the bookkeeping's system are isomorphic (2./T <sub>2</sub> /C <sub>2</sub> ). ....	80
<b>The uncontrolled bookkeeping and inventory through involved truth-untruth dilemma and the law of "square control"</b> .....	80
Theorem 3: We can not consider to 100 percent unto corresponding the data of the uncontrolled property bookkeeping registration with the real data of the occurred economic events in a given time-point t.....	80
Theorem 4: The uncontrolled inventory (that is: if it is unchecked with the documents of the corresponding economic events) does not prove the unfaulty of the uncontrolled bookkeeping and with its data made balance sheet (2./T <sub>4</sub> ). ....	82
Corollary 1: The uncontrolled (that is: with the document of the corresponding economic events and with the corresponding data of the controlled inventory unchecked) bookkeepeng events (account items) do not confirm (that is do not prove) the bookkeeping registration and by its data made balance sheet authenticity (2./T <sub>4</sub> /C <sub>1</sub> ). ....	83
Corollary 2: Let R <sub>i</sub> , R <sub>d</sub> , R <sub>b</sub> , R <sub>e</sub> denote on the straight the reality of on the same season relating inventory data, all document's data, all bookkeeping data and the all economic event's data. By itself neither the inventory's data (R <sub>i</sub> ) nor to the inventory season corresponding data (R <sub>d</sub> ) of the booked documents but yet the both together nor confirm the reality of the touched bookkeeping (R <sub>b</sub> ) and balance sheet but only the following four equality all at once: R <sub>e</sub> =R <sub>d</sub> and R <sub>d</sub> =R <sub>b</sub> and R <sub>b</sub> =R <sub>i</sub> and R <sub>e</sub> =R <sub>i</sub> (2./T <sub>4</sub> /C <sub>2</sub> ). This corollary is called the law of "square control" of the bookkeeping. ....	83
<b>Standardization and automatization</b> .....	83
Theorem 5: We can squarely assign a such finite set to any economist which consists its activity belonging from the standardized economic events (2./T <sub>5</sub> ). ....	83
Corollary 1: Let n denote the number of the abstract economic events ans k the number of the standardized economic events. On the relation of these holds: $1 \leq k \leq n$ ( $n=1,2,\dots$ ) [2./T <sub>5</sub> /C <sub>1</sub> ].....	84
Corollary 2: The standardized economic events are also typical on the economist's activity, that is: they are economist-specific [2./T <sub>5</sub> /C <sub>2</sub> ].....	84
Theorem 6: In the (0;t] interval ( $t=1,2,\dots,M$ ) let concrete bookkeeping events occur that are named with standardized economic events. Let us classify these bookkeeping events by types of these standardized economic events. Thereafter let	

us sum these gross property changes that are occurred apropos of these bookkeeping events. This time the got algebraic sum, which belongs to the  $M$ th time-point, is equal with the main sum of classification (by types of these standardized economic events) of the gross property changes (2./T<sub>6</sub>).....84

Theorem 7: We can assign squarely to all *standardized* economic event the to it corresponding to concrete bookkeeping event belonging event coordinates' data-vector  $\vec{y}_i^* = \vec{o}_i^*$  as meta data of the class-coherence [in the traditional bookkeeping it is called: to debit-credit account coherence] (2./T<sub>7</sub>).....85

Corollary: To all standardized economic event may be squarely to assign all such concrete data of to them corresponding concrete documented economic event what depend from these standardized economic event (2./T<sub>7</sub>/C).85

Theorem 8: The coordinates of some bookkeeping event of the economist may define automatically like the function of the economist-specific standardized economic events. (2./T<sub>8</sub>).....86

Corollary: If the  $e_i \rightarrow \vec{y}_i^* = [y_1, y_2, \dots, y_k]_i = \vec{o}_i^*$  is all for  $i$  correctly predefined then the class-coherent of any and any number of documented economic or rather bookkeeping events will be unfaulty when we give with event-coordinate designator automaton. That is if all event-coordinate designation unfaulty for all  $e_i$  then the use of the event-coordinate designator automaton excepts the faults of the event-coordinate designation. This one isolate the bookkeeping system from this type of the fault, for any  $e_i$  and all the same that how many times we repeat this operate. (2./T<sub>8</sub>/C).....86

Theorem 9: The data of some bookkeeping event of the economist may define automatically like the function of data pf the economist-specific standardized economic events and the concrete documented economic events with bookkeeping automaton (2./T<sub>9</sub>) .....86

Theorem10: The data of the (trial balance) cumulative statement what as the data of the A or C-aspect and the identification sign  $s_i \in S = \{s_1, s_2, \dots, s_i, \dots, s_p\}$  property's type (traditionally these called to ledger's accounts) may define with cumulative statement maker (trial balance query) automaton made from the data-base (2./T<sub>10</sub>). .....87

Corollary 1: We may make the balance sheet also with the cumulative statement maker (trial balance query) automaton from the bookkeeping database if we correspondently complete this automaton (2./T<sub>10</sub>/C<sub>1</sub>) . .....87

Corollary 2: If the property classification system is N-aspect ( $N \geq 2$ ) we can make then also the cumulative statement (trial balance) and/or the balance sheet if we correspondently complete automaton (2./T<sub>10</sub>/C<sub>2</sub>) . .....87

Corollary 3: For the use of the bookkeeping and the cumulative statement maker (trial balance query) automaton is unnecessary to make and to keep with computer or hand the traditionally ledger's accounts. Ergo the account theories in this situation are reason lost. *This situation is the death of the account theories* (2./T<sub>10</sub>/C<sub>3</sub>). .....87

**3. THE BASE ELEMENTS OF THEORY OF THE DEBIT AND CIRCLE-DEBIT ..... 88**

3.1 Principles..... 88

3.11 Definitions.....88

3.12 Market axioms.....88

3.2 The theorems of the debit and circle-debit and its proofs..... 88

Theorem 1: All creditors are simultaneously debtors too (3./T<sub>1</sub>). .....88

Theorem 2: The performers of the market are all economists of property (3./T<sub>2</sub>). .....89

Corollary: All seller is buyer also and vice versa (3./T<sub>2</sub>/C) . .....89

Theorem 3: If there are only two economists of property on a market then they owe only to one another. This time they, as debtor-pair, make that debtor-circle to which is minimal the number of its members. This one is the minimal case of the circle-debit. (3./T<sub>3</sub>).....89

Theorem 4: There is circle-debit on all market that is: the circle-debit is the attribute of the markets other their essential feature (3./T<sub>4</sub>). .....90

Corollary 1: If there is such debtor-circle on the n-performer market ( $n \geq 3$ ) which is not debtor-pair then any member of so debtor-circle may owes not only to one other circle-member. Thus such debtor-circle may be complex too (3./T<sub>4</sub>/C<sub>1</sub>). .....91

Corollary 2: Let P denote the number of the debtor-pair. The n-performer market (where  $n \geq 3$ ) may contain more debtor-pair also. The possible maximal number  $P_{max}$  of the debtor-pairs  $P_{max} = [(n-1)*n]/2$  what is equivalent e.g. with number of that lines what connect apexes of a convex n-angle (where  $n \geq 3$ ).  $P_{max} = [(n-1)*n]/2$  may verify easy with mathematical induction. [3./T<sub>4</sub>/C<sub>2</sub>]. .....91

Corollary 3: If the n-performer market (where  $n > 3$  and even), as a set, disintegrates on number k of market-segments (that is on subsets) where  $n = 2k$  then it may contains pieces k from one another independent debtor-pairs (3./T<sub>4</sub>/C<sub>3</sub>). ...91

Corollary 4: If the n-performer market (where  $n > 2$ ) disintegrates on market-segments then it may contains debtor-pair(s) and/or debtor-circle(s) with odd member (3./T<sub>4</sub>/C<sub>3</sub>). .....91

**PREFACE TO APPENDIXES ..... 92**

**APPENDIX 1..... 93**

**BOOKKEEPING OF PROPERTY AND ITS BALANCE SHEET..... 93**

**APPENDIX 2..... 96**

**BOOKKEEPING OF LEVEL OF KNOWLEDGE OF THE STUDENTS AND THE KNOWLEDGE BALANCE SHEET..... 96**

**APPENDIX 3..... 98**

**BOOKKEEPING OF THE MONTHLY TELEPHONE-COST AND THE MONTHLY COST BALANCE SHEET..... 98**

<b>APPENDIX 4.....</b>	<b>99</b>
<b>AN TO DAY USED HUNGARIAN, ENGLISH, AND A GERMAN CLASSIC BALANCE SHEET OF PROPERTY .....</b>	<b>99</b>
<b>APPENDIX 5.....</b>	<b>101</b>
<b>THE FACTS OF EXPERIMENT OF A PUBLICATION.....</b>	<b>101</b>
<b>APPLIED MAJOR NOTATION.....</b>	<b>105</b>

## THIRD PART

### PREFACE OF THE EDITION 2

My book<sup>1</sup>, with exception of its third part, was finished by the end of 2003, naturally Hungarian.<sup>2</sup> The scientific problem and the foreknowledge of the result already born in 1997; but I begin to write the book only in 2000.

The content, at that time, was the first and second part just as the appendix of the book, which was written on purpose to let it popularize this doctrine but let it not claim more knowledge than the popular education.

At that time seemed, I explicated already all important rudiments what I could tell with the traditional bookkeeping (aka: accountancy) or rather the modern N-entry (N-fold) ( $N \geq 3$ ) property bookkeeping related.

This time I read firstly the book<sup>3</sup> of Gábor Szász whose title is 'The axiomatic method' and which in 1972 issued. This section is about to how to became a true science of mathematics. Here Szász explicate that: *The Egyptians and the Babylonians have not the rules on their mathematical knowledge. That is, speaking of today's language, they are not established theorems only edited concrete numerical model examples, and on ones demonstrated the methods of calculation. The expressing forms of the today's mathematics, which ones in the schools are used as general expressions, for example the definition or the theorem or the axiom and the proof, developed out yet in the Ancient Greek culture. Meanwhile, the mathematics instead of empirical collection of knowledge has become a real deductive science.*

I realized promptly that the system of concepts of doctrine of the traditional bookkeeping is not exact. The bookkeeping's traditional doctrine, neither before Paccioli<sup>4</sup> nor from Paccioli ere now, has not nicely concepts and from this ones standing and uncontradicted and the system of built on each other concepts. This one has not axioms and verifying and built on each other theorems which ones form a coherent system. But this one is true on the so

---

<sup>1</sup> See the total book (438 p.) in Hungarian language in the Hungarian National Library (HNL=OSZK) ([http://www.oszk.hu/index\\_hu.htm](http://www.oszk.hu/index_hu.htm)) or in the Central Library of Corvinus University of Budapest ([www.lib.uni-corvinus.hu](http://www.lib.uni-corvinus.hu)) or in the Library of University of Pécs (<http://www.lib.pte.hu/>) or in the National Library of University of Debrecen (<http://www.lib.unideb.hu/>) or in the Library of Hungarian Central Statistics Office (HCSO) (<http://konyvtar.ksh.hu/index.htm>); additionally this third part of the book is free downloadable online from the home page of the Hungarian Electronic Library (HEL=MEK) here: (<http://mek.oszk.hu/07300/07350/>).

<sup>2</sup> See here: ([http://www.ginprofessional.hu/GI-A\\_modern\\_n-szeres\\_kvitel\\_20090814\\_01Rv\\_html-ben/N-szeres-kvitel\\_I\\_ajanj\\_2009\\_hu.html](http://www.ginprofessional.hu/GI-A_modern_n-szeres_kvitel_20090814_01Rv_html-ben/N-szeres-kvitel_I_ajanj_2009_hu.html)) and the 3<sup>rd</sup> part may free download.

<sup>3</sup> Gábor Szász: The axiomatic method (Textbook Publisher, Budapest, 1972), on the 20<sup>th</sup> page.

<sup>4</sup> Luca Paccioli: "Everything about Arithmetic, Geometry, and Proportions." on 24<sup>th</sup> page in the 11<sup>th</sup> tractate of the 3<sup>rd</sup> main part (Venice, 1494).

far completed modern doctrine of the N-entry ( $N \geq 3$ ) property bookkeeping too, although it has exact *definitions, axioms, theorems with them certain relations, but yet on the all theorems* extending without proofs.

Thus ***the bookkeeping's doctrine, as a science, in the current state, as it is, does not exceed from the empirical collection of knowledge standing, before 2500 years Egyptian and Babylonian level of the mathematics.***

But the possibilities were given from Euclid already at least to 2300 years. The possibility existed that let them describe on modern method the bookkeeping's doctrine also like to the already then developed mathematics and geometry.

However, the modern N-entry ( $N \geq 3$ ) bookkeeping was discoverable in the antiquity also, but in time of Paccioli already on all cases. Namely any economic event also occurred in, already in the antiquity also, never not showed only two, that is, by assets and capitals aspects of changes of the property and/or debt. The number of showed aspects is always at least three. For example: if we bought some product on credit then from the dates of the economic event known promptly the values of three parameters: i.e. (1) the time-point of the change and (2) the bought asset's type and (3) the source of purchase of the asset. (That is that in the case (3): What is the invested capital? Is it the foreign capital from credit or equity?) The triple (as triple of the event coordinates) of these three parameters promptly and on naturally method denoted out and such created or changed by the time- assets- and capital-aspect natural property classes, to which ones touched by this economic event as by property change. These coordinates of the economic event defined on naturally method from the time-assets-capital-aspect property classifications standing complete just as dynamic and static property classification system. Let us name by this example classification system to three-pen balance sheet. The bookkeepers (aka: accountants) and the professors of the bookkeeping ***did not realize up*** these ones by more then 2000 years.

In turn the triples of coordinates are attributes of the economic events, ever since the man economy; and these were and are always by the bookkeeper (accountant) known into the set of dates of the bookkeeping, if they on clay-table booked too. Only they ***did not realize up*** this one nor.

The traditional bookkeeping and its doctrine more then 2300 years across did not develop sufficiently. Paccioli wrote<sup>5</sup> down firstly, in 1494, the use of a rudimentary double-entry bookkeeping. He showed in the use of this on simple example across. After this, Shär created, in 1890, a closed system of the accounts (in German: 'Das geschlossene Kontensystem'<sup>6</sup>). Schmalenbach<sup>7</sup> and Kosiol, in 1933, dreamed the so-called dynamic balance sheets, but

<sup>5</sup> Luca Paccioli: "Everything about Arithmetic, Geometry, and Proportions." on 24<sup>th</sup> page in the 11<sup>th</sup> tractate of the 3<sup>rd</sup> main part (Venice, 1494).

<sup>6</sup> Schär, Johann, Friedrich: „Buchhaltung und Bilanz“, Berlin, 1914, 1919.

<sup>7</sup> Schmalenbach, Eugen: Dynamische Bilanz, 1933, Leipzig; Kosiol, Erich: Pagatorische Bilanz, 1976, Berlin.

these were in truth static balance sheets. Meanwhile doctrine of the bookkeeping, from Paccioli to Schmalenbach, got to the so-called account theories, which ones contain two or four sets of the accounts. [An example for the base equation of two sets of accounts is the follows:  $\text{Assets}=\text{Capitals}$ . And an example for the base equation of four sets of accounts is the follows:  $\text{Assets}=\text{Liabilities}+\text{Equity}+(\text{Yields}-\text{Costs})$ , where the each one term of the equation symbolize a set of accounts.] So the double-entry bookkeeping, over 400 years, altogether so much developed. In fact, the traditional doctrine of the bookkeeping, from 1910 to present, that is a whole century across, such materialized respect to the said minor changes. Otherwise it, without significant evolution, stagnated. The scientists to present describe that the so-called single-entry bookkeeping holds and it may use as a complete bookkeeping, which is fundamentally error. I verify this one also in this work. And they were not able to break with account theories after appearance of the personal computers, on end of the twentieth century began in the age of PC nor. Moreover, the software developers simply only imitate with their accounting programs the manual double-entry bookkeeping, so they only conserved in the old bookkeeping's existing knowledge and practice. I proof here this one too.

The evolution of the traditional bookkeeping and its doctrine, to present, got in dead end. What is more, this doctrine became straight orthodox. Therefore, early in 2004, I saw to unavoidable to attempt the setting up of elements of the bookkeeping. I saw that unavoidable to prove by the elements of the bookkeeping, that is, to prove by the bookkeeping's axiomatic system the existence of the  $N$ -entry ( $N \geq 3$ ) property bookkeeping just as the its features and by it opened wide space of opportunities. I also demonstrate here, on exact mode, that both the single-entry bookkeeping and the double-entry bookkeeping are incomplete. This one mainly today, in the age of PCs, hampers the supply with sufficient information the economic actors.

I decided on base of these. I suspended the preparations publishing of my book and commenced the compilation of the accounting elements. This has happened built on each other definitions, axioms, built on each other items with formulation and proof. Between these are more new too. This activity, which incorporates in coherent system the bookkeeping's elements, to a pleasant surprise, brought additional knowledge too. Although, in meantime illness and surgery and lengthy convalescence and my job prevented me in that I realize my goals. Now, however, I may publish the result here finally. This can be polished. This work can be refined or improved and expanded as well. (This second edition also shows this one.) But otherwise also it can be incorporated this axiomatic system. It is now already scientific commonplace and found fact. This is a found fact, if one compares for example the Euclidean and Bolyai-Lobachevski and Hilbert geometry, as axiomatic systems. However, it is also fact that the by me described axiomatic system of doctrine of modern bookkeeping will no longer

be avoided and can not be ignored, in my judgement, neither in the education nor in the scientific research. So, **with this moment the accounting's doctrine also crossed with the exact, clear and coherent concepts and axioms grounded between the deductive sciences. If 2300 years late, but over!** The bookkeeping's this modern doctrine with this has joined to the advanced and exact so-called justificative sciences. Already it was time.

It is important to note that: **This theory system does not do unusable and unavailable the present bookkeeping praxis.** However, it opens the way out of the development of this science before the modern satisfaction of the information's need of the management just as before the substantive development of the bookkeeping programs.

This work may be read my book (438 pages) in third chapter (the last ca. 100 pages); it one concentrated but high school level with knowledge also achieved doctrine of the modern accounting. Who wants a propagative-featured detailed explanations containing description I suggest to it read the first two parts of my book. Although as I mentioned this is currently accessible in Hungarian only.

I offer my book and its this part near the spontaneously interested readers to the

- scientific researchers,
- teachers and students of the bookkeeping,
- auditors and accountants,
- tax-experts,
- accounting legislatures,
- judges, prosecutors, lawyers,
- state tax officials and auditors,
- entrepreneurs and business owners,
- managers,
- and last but not least for the developers of the bookkeeping softwares.

\*\*\*

And finally let us look the following short story:

**Nobody can not be prophet in the own country! Consequently I also can not be.**

I offered my book on Hungarian and foreign edition (see in the 5<sup>th</sup> appendix the 2<sup>nd</sup> e-mail) to the Akadémia Kiadó Zrt. (to the Academy Publisher Co.) because I had no enough money to the private publication and on the requisitioning of a translator. The publisher firstly (on Thursday, September 03, 2009) favorably accepted the offer sithence this time requested authorization on previous examination of the handwriting by its economist experts (see in the 5<sup>th</sup> appendix the 3<sup>rd</sup> e-mail) with approximately one month period. I gave the authorization yet on the same day (see in the 5<sup>th</sup> appendix the 4<sup>th</sup> e-mail). I recommended yet on the next Tuesday that let the publisher apply, if possible, a mathematician expert too (see in the 5<sup>th</sup> appendix the 5<sup>th</sup> e-mail). They thanked

this suggestion within a half-hour (see in the 5<sup>th</sup> appendix the 6<sup>th</sup> e-mail). But to my surprise, yet on the same day three hours later, they sent an e-mail message that they do not intend to publish my book by the judgment of the experts (see in the 5<sup>th</sup> appendix the 7<sup>th</sup> e-mail). Justification was not.

I suspect that the some director of the publisher a mathematician expert on application done my offer considered to brusqueness or that writer, whose I nibbled at her work, swung the case.

Let us remember the case of János Bolyaí. He wrote his work from the non-Euclidean geometry in Latin language by then practice. This appeared in the appendix of book of his father to which title is Appendix of Tentamen. The work of János Bolyai unread lay on the shelf of the Hungarian Scientific Academy by decades without Hungarian translating. Finally, on great shame of president of the academy, a foreign publisher requested authorization to translate on French, English and Italian languages the famous mathematical work which yet then neither was translated on Hungarian language.

But what do I want? I am not János Bolyai and my book does not speak on the absolute science of the space. Still I so thought that the scientific world and the student of the theme must know the modern doctrine of the N-entry bookkeeping and its axiomatic system. Hence I started the translating of this part of my book on English language, firstly in my life. I know that this translating is not unfaulty; hence I apologize to the reader. But failing enough money I can realize my target only thus.

However, I hope that this work raises the interest of the sponsors and/or the publishers.

Budapest, 23 August 2010

István Gulyás  
Economist

**The grounds of the modern bookkeeping doctrine:  
The n-entry ( $n \geq 3$ ) bookkeeping theory's elements and  
its axiomatic system**

**1. The elements of the property theory of the bookkeeping**

**1.1 Principles**

**1.11 Definitions**

1.111 The concepts of theory of the general bookkeeping

1. Let the function  $\{C_1, C_2, \dots, C_n\} = f(C, R_e) = C_{R_e}$  express an partition operation, which between elements of the non-empty set  $C$  valid equivalence relation  $R_e$  according to mutually squarely assigns together the pair  $(C, R_e)$  and the all disjoint<sup>8</sup> subsets  $C_i$  ( $i=1, 2, \dots, n$ ) of  $C$ . I will name the operation  $C_{R_e}$  just as the output of  $C_{R_e}$  to **classification**, while the  $C$  and its all subsets  $C_i$  ( $i=1, 2, \dots, n$ ) by  $R_e$ , to **equivalence class** (or briefly: to **class**). The next statements, which applies to  $C$  and  $C_i$  ( $i=1, 2, \dots, n$ ), are true: (1)  $C_i \cap C_j = \emptyset$ , where  $i, j=1, 2, \dots, n$  and  $i \neq j$ ; (2)  $C_1 \cup C_2 \cup \dots \cup C_n = C$ ; (3) the two elements of  $C$  if and only if elements of a given  $C_i$  ( $i=1, 2, \dots, n$ ) if these elements are equivalent by  $R_e$ .<sup>9</sup> I will call the  $R_e$  to **classification aspect**<sup>10</sup>.
2. If we don't divide up a class to disjoint parts, then its name is **final class**, else **middle class**. The name of middle class is in addition **relative basic class** too. The primal set's name is **absolute basic class**, but if not divided, then its name is in addition final class too.
3. When in classes of a classification some measure function (e.g. quantity, monetary value, etc. of elements of the classes) defined then the value of one is called **main sum** if it belongs to

---

<sup>8</sup> **Disjoint** (sets/subsets) = these are such sets/subsets what have not common element.

<sup>9</sup>  $C$  may be a set of **existent** or **nonexistent** (e.g.: fictitious) **things**. E.g.: If  $C$  is the range of some genus idea, then the output  $\{C_1, C_2, \dots, C_n\}$  of  $C_{R_e}$  is the set of subgenus ideas (aka: species ideas) and these subgenus ideas create the range of genus idea. This time the function  $C_{R_e}$  corresponds to the conventional logic division, respectively at iteration to classification, where  $R_e$  is basic of the division or rather the classification. If now  $C$  is the set of some school's students, then the output  $\{C_1, C_2, \dots, C_n\}$  of  $C_{R_e}$  is the set of the school's classes, where the subset  $C_i$  is the set of students of the class  $i$  ( $i=1, 2, \dots, n$ ), if  $R_e$  dictates this. Nota bene! If input  $C$  is set of existent things, then the output classes are too. Else if input  $C$  is set of nonexistent things, then output classes are too, other cases, evidently, are not possible.

<sup>10</sup> **Aspect** is in viewpoint sense, in this theory.

the basic or middle class else **part sum** if it belongs to the final class.

4. Under the **structure of classification I understand** that the basic class how many and what for classes divides and its total sum how many and what for part sums divides.
5. The **static class is** such class, which contains or could contain in some time  $p$  ( $p \leq t$  and  $p, t = 1, 2, \dots$ ) of the interval<sup>11</sup>  $(0; t]$  in this part of the base class existing or<sup>12</sup> from that in  $p$ th time or before lost element(s) of one, according to the classification aspect. Such classification, which results in static classes, **is called static classification**, which always apply to a given moment  $p$ .
6. Let  $\mathcal{C}_{\text{CHAN}}$  and  $\mathcal{C}$  be two classes and let  $\mathcal{R}_e$  be an equivalence relation on the absolute or some relative basic class  $\mathcal{C}$  of elements.  $\mathcal{R}_e$  is the classification aspect by time. We say that: the **dynamic class**  $\mathcal{C}_{\text{CHAN}}$  or otherwise: the **class of the changes**  $\mathcal{C}_{\text{CHAN}}$  **is** so class of  $\mathcal{C}$  which contains or could contain element(s) of totality (other: doses of totality) according to the classification aspect  $\mathcal{R}_e$ , which or which ones got into the property and/or as additional element/elements of  $\mathcal{C}$  emerged from the totality in some time of the interval  $(r; t]$  ( $0 \leq r < t$ ;  $r$  and  $t$  is integer). We can say otherwise too: the dynamic class  $\mathcal{C}_{\text{CHAN}}$  contains or could contain all changes (increases and decreases) of the totality in  $(r; t]$  with respect to  $\mathcal{R}_e$ . The such classification, which results in dynamic classes, **is called dynamic classification**, which always apply to a given interval  $(r; t]$  and always shapes by totality's changes (other: by chronology of the events).
7. The **class of the decreases**  $\mathcal{C}_{\text{DECR}}$  **is** such part class of the change class  $\mathcal{C}_{\text{CHAN}}$  ( $\mathcal{C}_{\text{DECR}} \subseteq \mathcal{C}_{\text{CHAN}}$ ) which contains such object(s) of  $\mathcal{C}_{\text{CHAN}}$  which or which ones got into the totality in some time of an interval  $(r; t]$  (where  $0 \leq r < t$  and  $r, t$  are integer) or before (e.g. in the interval  $(0; r]$ ), and/or which or which ones, as additional element(s) of  $\mathcal{C}_{\text{CHAN}}$ , emerged from totality in some time of  $(r; t]$ . But an element  $x$  (element  $x$  of  $\mathcal{C}_{\text{CHAN}}$ ) which emerged from totality in the interval  $(r; t]$ , if and only if may be element  $x$  of  $\mathcal{C}_{\text{DECR}}$  too, if selfsame the element  $x$  got also into the  $\mathcal{C}_{\text{CHAN}}$  in the interval  $(r; t]$  or before (e.g. in the interval  $(0; r]$ ).
8. The difference class of the property change class  $\mathcal{C}_{\text{CHAN}}$  and the same aspect property decrease class  $\mathcal{C}_{\text{DECR}}$  in the interval  $(r; t]$  ( $0 \leq r < t$ ;  $r$  and  $t$  is integer) **is called class balance of the property** (briefly: **balance class**  $\mathcal{C}_{\text{CHAN}} - \mathcal{C}_{\text{DECR}} = \mathcal{C}_{\text{BAL}}$ ). To  $\mathcal{C}_{\text{CHAN}} - \mathcal{C}_{\text{DECR}} = \mathcal{C}_{\text{BAL}}$  is true:  $\mathcal{C}_{\text{BAL}} \cap \mathcal{C}_{\text{DECR}} = \emptyset$  and  $\mathcal{C}_{\text{BAL}} \cup \mathcal{C}_{\text{DECR}} = \mathcal{C}_{\text{CHAN}}$ . **Additionally:**

<sup>11</sup> If an interval is **closed from right**, then it is denoted e.g.  $(0; t]$ , where the left bracket is round, while the right bracket is square, and.  $t > 0$ . Additionally:  $t$  is end plus part of interval, but 0 is not.

<sup>12</sup> Remember: this word 'or' is exclusive or. See the footnote 3.

Since all elements of  $\mathcal{C}_{BAL}$  have such feature that these are in  $\mathcal{C}_{CHAN}$  or emerged from  $\mathcal{C}_{CHAN}$  yet in  $t$ th time point of interval  $(r;t]$ , hence this  $\mathcal{C}_{BAL}$  which belongs to interval  $(r;t]$ , we define, in addition, as a static property class which belongs to  $t$ th time point, if and only if (a)  $r=0$ , that is, if the to  $\mathcal{C}_{CHAN}$  and to  $\mathcal{C}_{DECR}$  and to  $\mathcal{C}_{BAL}$  belonging interval is  $(0;t]$ , or (b) has  $r \neq 0$ , then as balance class we consider the union of balance class of the interval  $(0;r]$  and balance class of the interval  $(r;t]$ .

9. To some dynamic class  $\mathcal{C}_{DYN}$  or rather to a static class  $\mathcal{C}_{STAT}$  belonging main or part sum equal to the difference (or other: balance) of quantity or monetary value (or value of positive coefficient linear transformation of these) of those objects which ones got into  $\mathcal{C}_{DYN}$  and emerged from there in the interval  $(r;t]$  ( $0 \leq r < t$ ;  $r$  and  $t$  is integer), or rather which ones are in  $\mathcal{C}_{STAT}$  and missing from there in the  $t$ th time point.
10. **Under the *complex* or *compound dynamic classification* we understand** that dynamic classification wherein we classify the objects of totality next to the time-aspect by other aspect too. If we e.g. classify by  $A_1$ -aspect too, then **we talk** from  $A_1$ -like else if we classify by  $A_2$ -aspect too, then **we talk** from  $A_1$ -like **complex dynamic classification**.
11. The **(in part and main sum) transformed classifications** are those classifications which differ only to their same classes ordered in one or more part sum and in main sum just as in their same measures but at least in their measures, by some transformation, but in other not.
12. The **classification with cumulated part sums** or other **cumulative dynamic classification**<sup>13</sup> is the such (in main and part sum) transformed classification whose to all  $n$ th classes ( $n=1,2,\dots,M$ ) ordered part sum equal with the first  $n$  classes' sum of without accumulation part sums. Consequently the its main sum is same with the  $M$ th time-aspect class belonging cumulated part sum, but is not same with the first  $M$  sum of the cumulated part sums.
13. **I will name to *attribute***<sup>14</sup> **classification** the clean time-aspect just as the clean static attribute-aspect classifications; furthermore any time-attribute-aspect complex dynamic classifications too, their part and main sums are either transformed or not. Such classification results **attribute classes**. **I will name** all other classification to **optional classification**.
14. **I name to *natural classification*** that occurrence when an events' supervention defines any class issue or change. **I name to *natural classes*** the so sprung or changed classes. The attribute classes **are natural classes** also in one block.

<sup>13</sup> See for example in the appendix 1 the table  $y_3$  and its diagrams.

<sup>14</sup> Attribute is that feature of some thing or set of things or rather some occurrence which is inseparable from it and without which it may not exist and it is unthinkable too.

15. **Under the *classification system I understand*** the totality of classes and one or more classifications of a given static base class and/or those changes what resulted the static base class, just as totality of to these classes belonging main and part sums.
16. **I name to *balance sheet*** that classification system which contains two or more different classifications of the base class, namely it contains two different attribute-aspect static or one dynamic and two different attribute-aspect static or all time-attribute-aspect dynamic classifications.
17. The main sums of classifications of the balance sheet **are called *main sums of balance sheet*** (aka: ***total sum***), the part sums of these classifications **are called *part sums of balance sheet***.
18. **I name to *satisfactorily informative*** the classification system if it contains at least the attribute-aspect static classifications and the clean time-aspect classification of the base class, or if it contains all time-attribute-aspect complex dynamic classification of the base class.
19. **I name to *closed*** the ***classification system*** the ***in point of the events*** what bring in its base class possible changes if and only if any so possible event results there are such part sums in the classification system which correspond to character of event and change by the content of event.
20. **I name to *complete a classification system*** if it is satisfactorily informative and closed in point of the events what bring in its base class possible changes.
21. ***Impossible event***<sup>15</sup> **is** that event whose apropos of resulting such part sum should change sign by which it is not possible about character of the class or the event.
22. **Under *coordinates of event*** (other: ***event coordinate n-tuple***) **I understand** by sequence of classifications of by the event touched classification system (or part system) ordered such data ***n-tuple*** or ***n-elements vector*** (where  $n \geq 2$ ) (if the classification system is part system, then  $n \geq 1$ ) which shows by element(s) that about the event which part sum of the final classes changes (increases or decreases) in the (part) classification system.<sup>16</sup>
23. The such event coordinate n-tuple **is *rational*** (other ***realistic***) which some possible event apropos of resulting in the classification system signs them and only them the classes, completely, whose the part sum must change by the event's character and content.

---

<sup>15</sup> The function of the impossible event is like as the function of the condition  $x \neq 0$  near the  $1/x$ . For example impossible events are the followings: from nothing take away something, or: from a negative quantity take away an in absolute value greater negative quantity so that the result is not positive.

<sup>16</sup> The event coordinate n-tuple shows the coherence of the ledger accounts apropos of some event in the traditional bookkeeping; that is it shows what accounts are changing.

24. **I name characteristic of the classification system** the numbers of you final classes of the system, by what, an event apropos of resulting the part sum change.
25. **Two classifications** of some classification system **are (one another) independent** in point of that events what go only with structural change, because if such event occur, then only the either classification's two final classes' part sums change in same absolute value but with opposed sign.
26. **Under the N-aspect or explicit N-fold (other: N-entry) ( $N \geq 3$ ) classification system I understand** that classification system, which contains in the defined time-point given at least the simple dynamic (that is, by time-aspect) just as the static attribute-aspect classifications of the base class, together.
27. **Under the implicit time-aspect or briefly implicit N-fold (other: N-entry) ( $N \geq 2$ ) classification system I understand** that classification system, which contains in the defined time point given base class's at least the time-attribute-aspect complex dynamic property classifications, together.
28. **I name to N-pan or other N-fold/N-entry balance sheet ( $N \geq 2$ ) the implicit N-fold/N-entry ( $N \geq 2$ ) or explicit N-fold/N-entry ( $N \geq 3$ ) classification system.**

#### 1.112 The concepts of property theory of the special property bookkeeping

1. **Under the gross property<sup>17</sup> we understand the totality or<sup>18</sup> the total quantity or the total monetary value of the property<sup>19</sup> constituent objects<sup>20</sup> of the economist<sup>21</sup> at a given time.**
2. **Let us express in same measure the gross property and the liability<sup>22</sup> (aka: foreign property or debt<sup>23</sup>). In such case under**

<sup>17</sup> The **gross property** also known as total property; it is in essence itself the any not reduced property. It has more valid definitions which in differing way approximate the essence. Example, in view of definition of the net property, one definition may be the next: The **gross property is** in same time point and by same measure expressed algebraic sum of the equity and the liability. (See also in theorem 5.)

<sup>18</sup> I use the word 'or' in this work always 'exclusive or' in sense opposite the expression 'and/or', whose local force I sign always plus.

<sup>19</sup> In this doctrine **the property** is undefined base idea. We may say on the property that it is the totality of own goods of the economist what have monetary values and they are marketable (other sellable) goods. These may be material and immaterial goods (we called the latter with other word: to rights).

<sup>20</sup> In this doctrine, the object of property is undefined base idea such as e.g. the next ideas: property, debt/liability, claim, debtor, lender, set/totality, subset, element of set, disjoint, union, intersection, empty set, equivalence relation, function, value of function, measure, quantity, monetary value, difference/balance, economic event, and economist.

<sup>21</sup> Under the **economist** (this is undefined base idea) we understand - to sum up - all economic forms, any establishment together with: natural and artificial persons, household of a family, furthermore: farmers, managers, and all private and state enterprises, companies, etc., in other words: everybody who has property and/or liability (debt).

<sup>22</sup> **Nota bene!** In this doctrine, that let it be exact theory system, under the **liabilities** (this is undefined base idea) **we understand** totality of whatever debits, **but not include** the equities idea like it is included sometimes in the traditional bookkeeping in the UK/US.

<sup>23</sup> **The liability** or other **the debt** is undefined base idea in this doctrine. It is onerous title of some economist which bears a relation to e.g. money or other object pass or rather else consideration completion. **Nota bene!** This onerous title is not marketable (or other: it is not sellable) because anybody buys claim but only crazy man buys debt ☺.

- the **net property** (aka: **equity**)<sup>24</sup> we understand the difference of the economist's gross property and **liability**, at a given time.
3. The **inventory is** at a given time findable (existing) individuals of **gross-** and **net property**, just as **debts** of the economist holistic review by quantity and monetary value, but at least by quantity.
  4. The **stock list** (other: **inventory output**) **is** with the stock taking obtained totality of **data**.
  5. The **property classification is** such classification the absolute basic class of which is same with the set of the assets in a given time or is same with the set of in a given interval occurred changes of property.
  6. **Element of the active property** (alias: the **asset**) **is** any object of the gross property if we classify it then we respect to that feature of it like its types or rather its economy<sup>25</sup> destiny, and we abstract from its all other features. **To the classification** respected feature **is called asset-aspect**. **Furthermore:** Under the **assets**<sup>26</sup> (other: under the **assets types**) we understand that **static or dynamic attribute property class** whose all elements are such objects which ones correspond to assets-aspect, or rather such objects through caused changes of active property, when these objects got into the dynamic property class and/or emerged from there. The base class of assets' two relative base classes **is named current assets** and **fixed assets**.<sup>27</sup>

<sup>24</sup> **Net property** is also known as equity or eigen capital (in US/UK), or rather eigen capital or own property (in central and east EU) in the traditional bookkeeping.

<sup>25</sup> I summarize in this book with the "**economy**" word the meanings of such various words as for example the 'farming', the "agriculture", the "housekeeping", the "husbandry", the "economization", the "industrial-economy" and the "money-economy", etc., additionally activity of the managers and all private and state enterprises, companies, etc. We may say that the economy is yon activity of the economist when it augments or use up its property some target on access or rather if it simply leaves that on itself. This latter obviously is the possible worst variant of economy.

<sup>26</sup> The assets are named to means of the economy in the central and east EU.

<sup>27</sup> **Example 1:** Let  $\mathcal{C}_A$  be the static base class of **assets**.  $\mathcal{C}_A$  contains the objects of the **gross property** in a given time  $t$  ( $t$  is a natural number) i.e.: one pound sterling  $\mathcal{L}$ , two dollars  $\mathcal{S}_1, \mathcal{S}_2$ , one euro  $\mathcal{E}$ , one pack paper  $p$ , two buildings  $b_1$  and  $b_2$ , three lands  $l_1, l_2$  and  $l_3$ . Thus we can define the assets base class by  $\mathcal{C}_A = \{\mathcal{L}, \mathcal{S}_1, \mathcal{S}_2, \mathcal{E}, p, b_1, b_2, l_1, l_2, l_3\}$ . (**Nota bene!** We may express the **assets** in quantity or in monetary value of objects like traditionally.) The first step of the static property classification: let  $\mathcal{R}_{CA}$  be a classification aspect according to assets' destiny it defined on  $\mathcal{C}_A$ .  $\mathcal{R}_{CA}$  is expressed by 'x  $\in \mathcal{C}_A$  is current asset'. Thus the classification  $\mathcal{C}_{\mathcal{R}_{CA}}$  with respect to  $\mathcal{R}_{CA}$  is expressed symbolically by  $\{\mathcal{C}_{CA}, \mathcal{C}_{NCA}\} = f(\mathcal{C}_A, \mathcal{R}_{CA}) = \mathcal{C}_{\mathcal{R}_{CA}}$ , where the part of result  $\mathcal{C}_{CA} = \{\mathcal{L}, \mathcal{S}_1, \mathcal{S}_2, \mathcal{E}, p\}$  is the class of the **current assets**. Now evidently:  $\mathcal{C}_{NCA}$  is the reminder of  $\mathcal{C}_A$  and  $\mathcal{C}_{NCA} = \{b_1, b_2, l_1, l_2, l_3\}$ . The  $\mathcal{C}_{NCA}$  may be other denoted e.g.  $\mathcal{C}_{FA}$  and its name is **fixed assets**. But the classification is repeatable. The next step may be the classification of  $\mathcal{C}_{CA}$ , defined by  $\mathcal{R}_{CM}$ .  $\mathcal{R}_{CM}$  is expressed by 'y  $\in \mathcal{C}_{CA}$  is money'. Now the operation is  $\{\mathcal{C}_M, \mathcal{C}_{NM}\} = f(\mathcal{C}_{CA}, \mathcal{R}_{CM}) = \mathcal{C}_{\mathcal{R}_{CM}}$ , where the part of result is class of the **moneys**  $\mathcal{C}_M = \{\mathcal{L}, \mathcal{S}_1, \mathcal{S}_2, \mathcal{E}\}$  while naturally:  $\mathcal{C}_{NM}$  is the reminder of  $\mathcal{C}_{CA}$ , that is  $\mathcal{C}_{NM} = \{p\}$ .  $\mathcal{C}_{NM}$  is called class of the **stocks**, it is denoted other  $\mathcal{C}_S$ . We can continue on the classification. The next step may be the classification of  $\mathcal{C}_{FA}$ , defined by  $\mathcal{R}_{CB}$ .  $\mathcal{R}_{CB}$  is expressed by 'z  $\in \mathcal{C}_{FA}$  is building'. Now the operation is  $\{\mathcal{C}_B, \mathcal{C}_{NB}\} = f(\mathcal{C}_{FA}, \mathcal{R}_{CB}) = \mathcal{C}_{\mathcal{R}_{CB}}$  where the part of result is class of the **buildings**  $\mathcal{C}_B = \{b_1, b_2\}$  while naturally:  $\mathcal{C}_{NB} = \mathcal{C}_L$  is the class of the **lands** ('L' denotes 'the lands'), it is the reminder of  $\mathcal{C}_{FA}$ , that is  $\mathcal{C}_L = \{l_1, l_2, l_3\}$ . So now the outcome of the static property classification  $\mathcal{C}_A$  contains the following two **middle classes** of the **assets**:  $\mathcal{C}_{CA}, \mathcal{C}_{FA}$ , plus four **final classes** of the **assets**:  $\mathcal{C}_M, \mathcal{C}_S, \mathcal{C}_B, \mathcal{C}_L$ . To these are true:  $\mathcal{C}_M \cap \mathcal{C}_S = \emptyset, \mathcal{C}_B \cap \mathcal{C}_L = \emptyset$  or rather  $\mathcal{C}_{CA} = \mathcal{C}_M \cup \mathcal{C}_S$  and  $\mathcal{C}_{FA} = \mathcal{C}_B \cup \mathcal{C}_L$  and  $\mathcal{C}_{CA} \cap \mathcal{C}_{FA} = \emptyset$  and  $\mathcal{C}_A = \mathcal{C}_{CA} \cup \mathcal{C}_{FA}$ . Finally the fallow statement is also true:  $\mathcal{C}_M \cup \mathcal{C}_S \cup \mathcal{C}_B \cup \mathcal{C}_L = \mathcal{C}_A$ .

7. Under the **assets-like classification** we understand all those classification in which ones we classify at least by assets-aspect.
8. Any object of the gross property which materializes in some asset and needed to economy (to economic activity), just as increases or decreases by means of economy **is called the element of the passive property** (or alias: **the capital**) if, when we classify it, then we respect its feature that: it is own of the economist (equity/eigen capital) or the economist owes with it to somebody (liability/foreign capital), and we abstract from its all other features. To the classification respected feature **is called capital-aspect. Additionally:** Under the **capitals**<sup>28</sup> (other: under the **capitals types**) we understand that **static or dynamic attribute property class** whose all elements are such objects which ones correspond to capital-aspect, or rather such objects through caused changes of passive property, when these objects got into the dynamic property class and/or emerged from there. The base classes of capitals' two relative base classes **are the foreign capitals** (traditionally: **liabilities**) and the **eigen capitals** (traditionally: **equity**<sup>29</sup>).<sup>30</sup>
9. Under the **capitals-like classification** we understand all those classification in which ones we classify at least by capital-aspect.

<sup>28</sup> The **capitals** are named as the **sources** of the property in the central and east EU.

<sup>29</sup> **Mind you!** In this doctrine, that let it exact, under the **liabilities** (this is undefined base idea) **we understand** totality of whatever debits, **but not include** the equities idea like it is included in the traditional bookkeeping in the UK/US.

<sup>30</sup> **Example 2:** Let  $\mathcal{C}_c$  be the static base class of **capitals**. But  $\mathcal{C}_c$  now also contains objects of the **gross property** in a given time  $t$  ( $t$  is a natural number) as before, i.e.: one pound sterling  $\pounds$ , two dollars  $\$, \$_2$ , one euro  $\text{€}$ , one pack paper  $p$ , two buildings  $b_1$  and  $b_2$ , or rather three lands  $l_1, l_2$  and  $l_3$ . This time we can define the base class of capitals by  $\mathcal{C}_c = \{\pounds, \$, \$_2, \text{€}, p, b_1, b_2, l_1, l_2, l_3\}$ , where let the  $\pounds, \$, \text{€}$  in class  $\mathcal{C}_c$  be **foreign capital** or rather let the one euro  $\text{€}$  be **long-term liability**, but other debit is not. Let the other dollar  $\$_2$  in class  $\mathcal{C}_c$  be **share capital** like money capital, while  $p$  and  $b_1$  are apported things. (**Nota bene!** We may express the capitals in quantity or in monetary value of objects like traditionally.) **In first step** let  $\mathcal{R}_{FC}$  be a classification aspect according to property objects' source, which defined on  $\mathcal{C}_c$ . This time  $\mathcal{R}_{FC}$  is expressed by 'x  $\in \mathcal{C}_c$  is foreign capital alias liability'. Thus the static property classification  $\mathcal{C}_{\mathcal{R}_{FC}}$  with respect to  $\mathcal{R}_{FC}$  is expressed symbolically by  $\{\mathcal{C}_{FC}, \mathcal{C}_{NFC}\} = f(\mathcal{C}_c, \mathcal{R}_{FC}) = \mathcal{C}_{\mathcal{R}_{FC}}$ , where the part of result  $\mathcal{C}_{FC} = \{\pounds, \$, \text{€}\}$  is the class of the **foreign capitals** alias **liabilities**. Evidently that  $\mathcal{C}_{NFC}$  is the reminder of  $\mathcal{C}_c$  and  $\mathcal{C}_{NFC} = \{\$2, p, b_1, b_2, l_1, l_2, l_3\}$ . The class  $\mathcal{C}_{NFC}$  may be other denoted e.g.  $\mathcal{C}_{EC}$  and its name is **eigen capitals** alias **equity**. This classification is also repeatable. **The second step** may be the classification of  $\mathcal{C}_{FC}$ , defined by  $\mathcal{R}_{FCL}$ .  $\mathcal{R}_{FCL}$  is expressed by 'y  $\in \mathcal{C}_{FC}$  is long-term liability'. Now the operation is  $\{\mathcal{C}_{FCL}, \mathcal{C}_{NFCL}\} = f(\mathcal{C}_{FC}, \mathcal{R}_{FCL}) = \mathcal{C}_{\mathcal{R}_{FCL}}$ , where the part of result is class of the long-term liabilities  $\mathcal{C}_{FCL} = \{\text{€}\}$  while naturally:  $\mathcal{C}_{NFCL}$  is the reminder of  $\mathcal{C}_{FC}$ , that is  $\mathcal{C}_{NFCL} = \{\pounds, \$, \$_2\}$ , where  $\mathcal{C}_{NFCL}$  is called class of the **current liability**, it is denoted  $\mathcal{C}_{FCC}$ . We can continue on the classification. **The third step** may be the classification of  $\mathcal{C}_{EC}$ , defined by  $\mathcal{R}_{ECS}$ .  $\mathcal{R}_{ECS}$  is expressed by 'z  $\in \mathcal{C}_{EC}$  is share capital'. Now the operation is  $\{\mathcal{C}_{ECS}, \mathcal{C}_{NECS}\} = f(\mathcal{C}_{EC}, \mathcal{R}_{ECS}) = \mathcal{C}_{\mathcal{R}_{ECS}}$  where the part of result is class of the **share capital**  $\mathcal{C}_{ECS} = \{\$2, p, b_1\}$  while naturally:  $\mathcal{C}_{NECS} = \mathcal{C}_{ECO}$  is the class of the **other eigen capitals** ('O' denotes 'other'), it is the reminder of  $\mathcal{C}_{EC}$ , that is  $\mathcal{C}_{ECO} = \{b_2, l_1, l_2, l_3\}$ . **The fourth step** may be the classification of  $\mathcal{C}_{ECS}$ , defined by  $\mathcal{R}_{ECSA}$ .  $\mathcal{R}_{ECSA}$  is expressed by 'u  $\in \mathcal{C}_{ECS}$  is apport part of share capital'. The operation is  $\{\mathcal{C}_{ECSM}, \mathcal{C}_{NECSM}\} = f(\mathcal{C}_{ECS}, \mathcal{R}_{ECSA}) = \mathcal{C}_{\mathcal{R}_{ECSA}}$  where the part of result is class of the **money of share capital**  $\mathcal{C}_{ECSM} = \{\$2\}$  while  $\mathcal{C}_{NECSM} = \mathcal{C}_{ECSA}$  is the class of the **apport of share capital** ('A' denotes 'apport'), it is the reminder of  $\mathcal{C}_{ECS}$ , that is  $\mathcal{C}_{ECSA} = \{p, b_1\}$ . So now the outcome of the static property classification  $\mathcal{C}_A$  contains the following three **middle classes** of the **capitals**:  $\mathcal{C}_{FC}$ ,  $\mathcal{C}_{EC}$  and  $\mathcal{C}_{ECS}$  plus five **final classes** of the **capitals**:  $\mathcal{C}_{FCL}$ ,  $\mathcal{C}_{FCC}$ ,  $\mathcal{C}_{ECSM}$ ,  $\mathcal{C}_{ECSA}$  and  $\mathcal{C}_{ECO}$ . The fallow statements are true: the pairs of the final classes are empty together with:  $\mathcal{C}_c = \mathcal{C}_{FC} \cup \mathcal{C}_{EC}$ ,  $\mathcal{C}_{FC} = \mathcal{C}_{FCL} \cup \mathcal{C}_{FCC}$ ,  $\mathcal{C}_{EC} = \mathcal{C}_{ECS} \cup \mathcal{C}_{ECO}$  and  $\mathcal{C}_{ECS} = \mathcal{C}_{ECSM} \cup \mathcal{C}_{ECSA}$ . Finally: the statement is also true:  $\mathcal{C}_{FCL} \cup \mathcal{C}_{FCC} \cup \mathcal{C}_{ECSM} \cup \mathcal{C}_{ECSA} \cup \mathcal{C}_{ECO} = \mathcal{C}_c$ .

10. Let  $(r;t]$  be some interval ( $0 \leq r < t$  and  $r, t$  integer) and let  $M$  be the number ( $M=2,3,\dots$ ) of all disjoint subinterval of  $(r;t]$ . Near this conditions that dynamic attribute property classification which classifies the changes of in the time  $t$  of interval  $(r;t]$  existing gross property or its some part in  $M$  disjoint final time classes, by moment of the changes **is called time-aspect attribute property classification** (or briefly: **time classification**). In case of time classification, we abstract from all features of the any classified object except that: the property's object got into the property, or rather emerged from the property in the interval  $(r;t]$  or in any given part of  $(r;t]$ , that is, it this time increase or decrease the property. At the time classification, two objects of the property then may get in same interval (in same time class) if both got into the property, or rather emerged from the property in same time class.<sup>31</sup>
11. **Under the debt-like classification we understand** the such part of the capital-like property classification in which we classify in the debt subclass belonging objects of property (that is the foreign capital's objects) by not time-aspect but by other aspect.
12. **We name to base capital** or to **subscribed capital** (aka: to **share capital**), to sum up: to **startup capital**, yon part sum of one final class of the eigen capital (alias equity), which shows that, when the economist began to manage, then it has how much gross property. At modification, it shows that, how much other property did it have to invest, as capital lifting, additional and eventual, or how much property did it have to extract, as capital cutting, from the economy.
13. **We name to reserve capital** (aka: **capital surplus**) yon part sum of one final class of the eigen capital (alias equity), which shows that the owner(s) or other(s) when and how much other property did it/they have to invest eventual into the economy, or how much property did it/they have to extract from there, not counting the startup capital.
14. **Under the cumulated yield (value)** in the  $t$ th time point ( $t=1,2,\dots$ ) **must be understand** the increment of the eigen capital (alias equity) which was obtain in interval  $(0;t]$  of economy, but not included the increment of the startup and/or reserve capital. This equity's increment may materialize in shape

---

<sup>31</sup> **Example 3:** Let  $\mathcal{C}_{CH,(0,1]}$  be class of the property change in the interval  $(0;1]$ , that is  $\mathcal{C}_{CH,(0,1]} = \{L, \$1, \$2, \$3, \text{€}, p, h\}$ , cf. example 1 and 2. Let  $\mathcal{C}_{CH,(1,2]}$  be class of the property change in the interval  $(1,2]$ , that is  $\mathcal{C}_{CH,(1,2]} = \{-\$3, b_2, l_1, l_2, l_3\}$ . Here '-\\$3' is a property object which emerged from the property and '-' symbolizes case of the emergence. Furthermore let  $\mathcal{C}_{CH,(0,2]}$  be class of the property change in the interval  $(0;2]$ , but  $\mathcal{C}_{CH,(0,2]} = \mathcal{C}_{CH,(0,1]} \cup \mathcal{C}_{CH,(1,2]}$ , cf. definition 19, and thus we may write  $\mathcal{C}_{CH,(0,2]} = \{L, \$1, \$2, \$3, -\$3, \text{€}, p, h, b_2, l_1, l_2, l_3\}$ . Now let  $\mathcal{C}_{DECR,(0,2]}$  be class of the property decrease in the interval  $(0;2]$ , that is:  $\mathcal{C}_{DECR,(0,2]} = \{\$3, -\$3\}$ . Consequently the fallow express is true by definition 9, 10 and 11:  $\mathcal{C}_{CH,(0,2]} - \mathcal{C}_{DECR,(0,2]} = \mathcal{C}_{BAL,(0,2]} = \{L, \$1, \$2, \text{€}, p, h, b_2, l_1, l_2, l_3\}$ . However the fallow express also is true:  $\mathcal{C}_{BAL,(0,2]} = \mathcal{C}_{A,2} = \{L, \$1, \$2, \text{€}, p, b_1, b_2, l_1, l_2, l_3\}$ , where  $\mathcal{C}_{A,2}$  is a static property class in time 2 of the interval  $(0;2]$  and it is equal to the balance class  $\mathcal{C}_{BAL,(0,2]}$ , cf. def. 11.

of any cash income, received goods or services (to barter also) or recognized claim, furthermore the property's natural increment or rather debit's release. This increment equal with the part sum of the cumulated yield class named final class of the equity named static relative base class in the  $t$ th time point.

15. **Under the *current period yield we understand*** the difference of cumulated yields of the current and a previous period.
16. **Under the *cumulated costs (value)*** in the  $t$ th time point ( $t=1,2,\dots$ ) **must be understand** that decrement of the eigen capital (alias equity) which eventuated in interval  $(0;t]$  of economy, but not included the decrement of the startup and/or reserve capital. This equity's decrement, within this the increment of loss, may materialize in shape of any used of the assets, eventual disbursement,<sup>32</sup> given goods or services (to barter also) or issued liability, additionally the property's natural decrement or rather credit's release. This decrement equal with the part sum of the cumulated costs class named final class of the equity named static relative base class in the  $t$ th time point.
17. **Under the *current period costs we understand*** the difference of cumulated costs of the current and a previous period.
18. **Under the *cumulated gross result* or other: *cumulated untaxed result we understand*** the algebraic sum of the cumulated yield and the cumulated costs.
19. **Under the *current period* (annual, terminal, monthly, etc.) *gross result* or other: *current period untaxed result we understand*** the algebraic sum of the current period yield and the current period costs.
20. If the cumulated or current period gross result less then zero, then it **is called *cumulated*** or rather ***current period loss***<sup>33</sup>, else if greater then zero, then it **is called *cumulated*** or rather ***current period profit***<sup>34</sup>.
21. **I name to *property balance sheet*** that balance sheet which contains two or more different but at least static assets- and capitals-aspect or dynamic time- and static assets- and capitals-aspect or time-assets- and time-capitals-aspect property classifications.
22. **I name to *classical balance sheet***<sup>35</sup> that property's balance sheet which has only two classifications, assets and capital static property classifications, and its part and main sums are expressed in monetary value.
23. **Under the *economist's material position I understand*** size of the gross and net property just as liability (aka: foreign

---

<sup>32</sup> All costs are expenses, sooner or later, but not all expenses (such as those incurred in acquisition of an income-generating asset) are costs.

<sup>33</sup> The *loss* is undefined base idea in the traditional bookkeeping and it is same with the decrement of own property of the economist. The loss may materialize in whatsoever form of the property.

<sup>34</sup> The *profit* is undefined base idea in the traditional bookkeeping and it is same with the increment of own property of the economist. The profit also may materialize in whatsoever form of the property.

<sup>35</sup> See for example the appendix 4.

property or all sorts of debt), at a given time; additionally structures of its property's classes and part sums.

24. **I name to *satisfactorily informative*** the property classification system if it shows the economist's material position in a given time and at least the changes of its gross property to this time by the time-aspect property classification.
25. **Under on *economist typical* or *economist-specific economic event* I understand** a given economist's or economist types' economic activity's (economy's) on effect, just as this economist's economic and/or social-natural environment on effect in the economy occurred totality of the economic event types.
26. **I name to *closed*** the economist's ***property classification system in point of the economist-specific economic events***, if and only if any so economic event results there are such part sums in the property classification system which correspond to character of event and change by the content of event.
27. **I name to *complete a property classification system*** if it is satisfactorily informative and closed in point of the economist-specific economic events.
28. **Under the *N-aspect* or *explicit N-fold* (other: *N-entry*) ( $N \geq 3$ ) ***property classification system* I understand** that property classification system, which contains in the defined time-point given at least the simple dynamic (that is, by time-aspect) just as the static assets-aspect and static capital-aspect property classifications of the gross property, together.**
29. **Under the *implicit time-aspect* or briefly *implicit N-fold* (other: *N-entry*) ( $N \geq 2$ ) ***property classification system* I understand** that property classification system, which contains in the ***defined*** time point given gross property's at least the time-aspect and the capital-aspect complex dynamic property classifications, together.**
30. **I name to *N-pan* or other *N-fold/N-entry balance sheet* ( $N \geq 2$ )** the gross property's implicit N-fold/N-entry ( $N \geq 2$ ) or explicit N-fold/N-entry ( $N \geq 3$ ) property classification system.
31. **I name to (*real*) *dynamic property balance sheet*** the implicit time-aspect or other implicit N-fold/N-entry ( $N \geq 2$ ) property classification balance sheet, while let the explicit N-fold/N-entry ( $N \geq 3$ ) property classification balance sheet's name be dynamic and static property balance sheet.

## 1.12 Axioms<sup>36</sup>

### 1.121 The axioms of the property and other chronologic sets

---

<sup>36</sup> The *axiom* is such statement of a theory system what we accept without proof to true and use the theorems of the theory on proof. *Nota bene!* The axiom-system of a theory may be different. There is example on this one in the geometry too. The geometric axioms of Elements of Euclid and the geometric system of Hilbert are so. This theory of the modern N-entry bookkeeping also can build up other axioms. But this time it is possible that some axiom will be verifiable theorem. I chose, after elaborate think, those axioms what are readable in this book.

1. If in some time point an assets-aspect static property class is non-empty, that is, one or more object(s) of property is/are in it, if and only if its main or part sum, which expresses the quantity<sup>37</sup> of this/these object(s) of property, is greater than zero ( $A_1$ ).  
P.<sup>38</sup>: 1./ $T_1$ .
2. If in a given time point some static class is empty, if and only if its main or part sum equal to zero ( $A_2$ ).  
P.: 1./ $T_3, T_4, T_5, T_7, T_{11}, T_{12}, T_{13}, T_{14}, T_{18}, T_{19}, T_{21}, T_{23}, T_{24}, T_{29}$ .
3. The monetary value of any thing, that is its unit price, may be only positive number<sup>39</sup> ( $A_3$ ).  
P.: 1./ $T_1$ .
4. If on classes of some classification, which ones are pairwise disjointed, is interpreted some measure function (or its positive coefficient linear transformation), then by this function to the final classes ordered sum of part sums equal to the base class ordered with main sum ( $A_4$ ).  
P.: 1./ $T_1, T_{11}, T_{16}, T_{19}, T_{28}$ .
5. Let  $\mathcal{C}_{CHAN}$  be a dynamic class of the changes,  $\mathcal{C}_{DECR}$  a dynamic class of the decreases and  $\mathcal{C}_{BAL}^D$  their dynamic difference (other balance) class ( $\mathcal{C}_{CHAN} - \mathcal{C}_{DECR} = \mathcal{C}_{BAL}^D$ ) in the  $(0;t]$  interval ( $t=1,2,\dots$ ). Additionally let  $\mathcal{C}_{BAL}^S$  be the static class which came into existence as the result of changes in  $t$ th time-point, and on which is true that  $\mathcal{C}_{BAL}^S = \mathcal{C}_{BAL}^D$ . This time in the change class  $\mathcal{C}_{CHAN}$ , in the  $(0;t]$  interval, apropos of the events came into existence difference (if the sign of the decreases is negative then algebraic sum) of increases and/or decreases, that is the main sum of  $\mathcal{C}_{CHAN} - \mathcal{C}_{DECR} = \mathcal{C}_{BAL}^D$  equal to the static class  $\mathcal{C}_{BAL}^S$  in the  $t$ th time point belonging with sum, let it be either main or part sum ( $A_5$ ).<sup>40</sup>  
P.: 1./ $T_{11}, T_{16}, T_{27}, T_{28}$ .
6. An absolute or relative base class has not two same classifications ( $A_6$ ).  
P.: 1./  $T_1, T_{16}, T_{17}, T_{18}$ .
7. If the economist leaves to itself its property or any part of it, then its size and monetary value, but leastwise monetary value (or other positive coefficient linear transformation's value), the natural and/or the social and/or the economic environment through generated economic events to impression, with the lapse of time monotonous decreases and tends to zero ( $A_7$ ).  
P.: 1./ $T_{15}, T_{17}, T_{29}$ .

<sup>37</sup> If this quantity of the property is monetary quantity, then clear that its notation in addition monetary value of the property too.

<sup>38</sup> A "P.:" utáni felsorolás azt mutatja meg, hogy az állítás mely következő tételben van premisszaként felhasználva.

<sup>39</sup> Naturally there is such case when there is not demand of some object of the property and hence its market-price is zero. But it has positive value as to waste evidently thus too.

<sup>40</sup> This axiom could be theorem also because it may proof by definitions of the dynamic and static classes just as its main and part sum. But I cut this for didactical causes.

## 1.122 Debt axioms

8. If the economist has property in some time, then it has debt too, which's size, by same measure, is equal or not equal compared to the property's size; but then if it has not property, then it has not debt neither or it has only debt; and other case is not possible ( $A_8$ ).
- P.: 1./ $T_3$ , 3./ $T_1$ ,  $T_3$ ,  $T_4$ .
9. The debtor economist has creditor and debt, with which it owes to creditor; its creditor now has property in claim form, to which it may claim from its debtor ( $A_9$ ).
- P.: 1./ $T_2$ , 3./ $T_1$ ,  $T_3$ ,  $T_4$ .
10. In a given time existing debt of the debtor equal its creditor's or creditors' with total claim which opposite with it now existing ( $A_{10}$ ).
- P.: 1./ $T_2$ .
11. If the economist leaves to itself its the property or any part of it, then its debt' measure, the natural or the social or the economic environment through generated economic events to impression, with the lapse of time monotonous increases and tends to the plus infinite ( $A_{11}$ ).
- P.: 1./ $T_{15}$ ,  $T_{17}$ .

## 1.123 Economic and general event axioms

12. Economic event occurs only the economist's economy activity or the natural or the social or rather the economic environment to impression ( $A_{12}$ ).
- P.: 1./ $T_{15}$ ,  $T_{19}$ .
13. If some event happened then the followings are known at least: (1) name of that collude/ wherewith happened this event, (2) time of the event, (3) name or description of the event, from which it is possible to deduce in the classification system to changed part sums belonging final classes, (4) quantity and/or monetary or other value of the change (and/or value of other positive coefficient linear transformation of these) ( $A_{13}$ ). **I will name this base theorem (this axiom) to the law of the event-attributes.**
- P.: 1./ $T_{15}$ ,  $T_{19}$ .
14. To the events' to changed part sum, within time classes, belonging final classes and its change character marked data (that is the event-name or event-description) and the event coordinates are equivalent, by their meaning, just as mutually and squarely correspond to one another ( $A_{14}$ ).
- P.: 1./ $T_{19}$ , 2./ $T_7$ .
15. In some  $t$ th time point ( $t=1,2,\dots$ ) occurred apropos of economic event into the touched property classification (a) only final class' part sum increase with an amount  $\Delta X$  ( $\Delta X > 0$ ), or (b) decrease with  $\Delta X$  (to the decrease, let  $c$  denote, holds:  $c = -\Delta X < 0$ ),

or (c) either final class' part sum decrease with  $\Delta X$ , while an other final class' part sum increase with the selfsame  $\Delta X$  (let us name the event in the case [c] to only structure-change or briefly compensative economic event). Other character elemental property change apropos of economic event is not possible ( $A_{15}$ ).  
P.: 1./ $T_9$ ,  $T_{19}$ . 3./ $T_6$ .

16. Between the economic events there are such which ones not touch the economist's monetary means ( $A_{16}$ ).

P.: 1./ $T_{17}$ ,  $T_{22}$ .

## 1.2 The theorems of the property theory and their proofs

The proofs of the following property theory theorems have with such important feature that, in these, I do not refer to bookkeeping rules, although in these ones, I tell from the property theory of the bookkeeping. Namely, this one is my basic strategical target when I build up the bookkeeping's property theory, because only such it may be to show out convincingly that the main factors of the material position, that is: the property and the debt and their character of the changes in the time, define the nature of bookkeeping and not inversely.

### Attribute classifications and their features of the classes

Theorem 1: If the economist has property in the  $t$ th time point ( $t=1,2,\dots$ ), then in this property or rather in its any non-empty assets-aspect static property class belonging goods' quantity or monetary value (or other characteristic's measure) marker main or part sum is possible only positive number<sup>41</sup> ( $T_1$ ).

By the condition, just as according to the inventory and/or the books the economist has property<sup>42</sup> in the  $t$ th time point ( $t=1,2,\dots$ ). Let us class, fully, in the property belonging goods by assets-aspect (other by property types)  $i$  ( $i=1,2,\dots$ ) different (see: axiom  $A_6$ ) to static final property classes. Let  $\mathcal{C}$  be non-empty and undivided set (base class) of goods of this property. Additionally, let  $\mathcal{C}_1, \mathcal{C}_2, \dots, \mathcal{C}_i, \dots, \mathcal{C}_n$  be the all pairwise disjoint final classes of  $\mathcal{C}$ , which ones symbolize the non-empty final classes of types of the objects of property.

Now let us order to the single final property classes, separately, in the  $t$ th time point into the property classes categorized property's objects' quantities, which ones are denoted by  $q_i$  (for all  $i$ ), and monetary values, which ones are denoted by  $v_i$  (for all  $i$  too), as this property classification's on classes defined values of functions. Let  $q_i(C_i)$  denote so the quantity of the objects of property, as function of  $C_i$ , by types of property

<sup>41</sup> Here and later under the numbers, if it is not index, we understand always rational numbers.

<sup>42</sup> In the future, if it is not dubious, under the property I understand always the gross property, for the sake of the briefness.

(that is, by final classes). Let it express the total sum of these quantities  $q_i(C_i)$  (for all  $i$ ), aside from denoting of single natural measures and the  $t$ th time point by follow equality:

$$q_1(\mathbf{C}_1)+q_2(\mathbf{C}_2)+\dots+q_i(\mathbf{C}_i)+\dots+q_n(\mathbf{C}_n)=\sum_{i=1}^n q_i(\mathbf{C}_i).$$

Now let  $P_{GR}^q(C)$  denote this classification's the main sum, which expresses the total quantity of goods, as function of  $C$ .

Additionally let  $v_i(\mathbf{C}_i)$  (for all  $i$ ) denote value of quantity of the types of goods, which ones expressed in same currency. This time let it expresses the total sum of  $v_i(\mathbf{C}_i)$  for all  $i$ :

$$v_1(\mathbf{C}_1)+v_2(\mathbf{C}_2)+\dots+v_i(\mathbf{C}_i)+\dots+v_n(\mathbf{C}_n)=\sum_{i=1}^n v_i(\mathbf{C}_i).$$

Let  $P_{GR}^v(C)$  denote this classification's your main sum, which expresses the total monetary value of goods, also as function of  $C$ .

Let  $p_1(C_1), p_2(C_2), \dots, p_i(C_i), \dots, p_n(C_n)$  denote still the (average) unit prices of single types of the goods. The  $p_i(C_i)$  (for all  $i$ ) is function of  $C_i$ , where  $p_i$  denotes the (average) unit price.

Now let us show that

- (1)  $q_i(C_i) > 0$  for all  $i$ ,
- (2)  $P_{GR}^q(\mathbf{C}) = q_1(\mathbf{C}_1) + q_2(\mathbf{C}_2) + \dots + q_i(\mathbf{C}_i) + \dots + q_n(\mathbf{C}_n) = \sum_{i=1}^n q_i(\mathbf{C}_i) > 0$ ,
- (3)  $q_i(\mathbf{C}_i) \cdot p_i(\mathbf{C}_i) = v_i(\mathbf{C}_i) > 0$  for all  $i$ , and
- (4)  $P_{GR}^v(\mathbf{C}) = v_1(\mathbf{C}_1) + v_2(\mathbf{C}_2) + \dots + v_i(\mathbf{C}_i) + \dots + v_n(\mathbf{C}_n) = \sum_{i=1}^n v_i(\mathbf{C}_i) > 0$ .

In the non-empty assets-aspect final property class  $\mathbf{C}_i$  (for all  $i$ ) and in the  $t$ th time point existing property's objects' quantity expressing part sum  $q_i(\mathbf{C}_i)$  (for all  $i$ ) may be only positive number, by axiom  $A_1$ . But the unit price  $p_i(\mathbf{C}_i)$  which belongs the final property class  $\mathbf{C}_i$  (for all  $i$ ) also may be only positive number, by axiom  $A_3$ . Thus clear that  $q_i(\mathbf{C}_i) \cdot p_i(\mathbf{C}_i) = v_i(\mathbf{C}_i) > 0$  for all  $i$ , because the product of positive numbers is positive.

Consequently:  $q_i(\mathbf{C}_i), p_i(\mathbf{C}_i), q_i(\mathbf{C}_i) \cdot p_i(\mathbf{C}_i) = v_i(\mathbf{C}_i) > 0$ <sup>43</sup> (for all  $i$ ), just as since the sum of the positive numbers is positive, so

$$\sum_{i=1}^n q_i(\mathbf{C}_i) > 0 \text{ and } \sum_{i=1}^n v_i(\mathbf{C}_i) > 0 \text{ (for all } i \text{)}.$$

Additionally: The next statement applies by axiom  $A_4$ :

"If on classes of a property classification, which ones are pairwise disjoint, is interpreted some measure function (or its positive coefficient linear transformation), then by this function to the final classes ordered sum of part sums equal to the base class ordered with main sum ( $A_4$ )."

This time the follow two equalities are true:

<sup>43</sup> Let us agree in that: if a relation's on some side two or more variables perform, are separating with comma, then on the other side being value or expression applies to all variables one by one.

$$P_{GR}^q(\mathbf{e}) = q_1(\mathbf{e}_1) + q_2(\mathbf{e}_2) + \dots + q_i(\mathbf{e}_i) + \dots + q_n(\mathbf{e}_n) = \sum_{i=1}^n q_i(\mathbf{e}_i), \text{ just as}$$

$$P_{GR}^v(\mathbf{e}) = v_1(\mathbf{e}_1) + v_2(\mathbf{e}_2) + \dots + v_i(\mathbf{e}_i) + \dots + v_n(\mathbf{e}_n) = \sum_{i=1}^n q_i(\mathbf{e}_i) \cdot p_i(\mathbf{e}_i) = \sum_{i=1}^n v_i(\mathbf{e}_i).$$

Now since  $P_{GR}^q(\mathbf{e}) = \sum_{i=1}^n q_i(\mathbf{e}_i)$  and  $\sum_{i=1}^n q_i(\mathbf{e}_i) > 0$  is true, just as because

$$P_{GR}^v(\mathbf{e}) = \sum_{i=1}^n v_i(\mathbf{e}_i) \text{ and } \sum_{i=1}^n v_i(\mathbf{e}_i) > 0 \text{ is also true, consequently } P_{GR}^q(\mathbf{e}) > 0$$

and  $P_{GR}^v(\mathbf{e}) > 0$  is also true.

But we obtain also this, if we sum the  $q_i(\mathbf{e}_i) > 0$  numbers for all  $i$  and the  $v_i(\mathbf{e}_i) > 0$  numbers for all  $i$ , since the sum of the positive numbers is positive.

Consequently the (1), (2), (3) and (4) statements and thus the theorem 1 are true. Q.e.d.

P.<sup>44</sup>: 1./T<sub>2</sub>, T<sub>3</sub>, T<sub>4</sub>, T<sub>5</sub>, T<sub>6</sub>, T<sub>7</sub>, T<sub>8</sub>, T<sub>9</sub>, T<sub>11</sub>, T<sub>12</sub>, T<sub>14</sub>, T<sub>15</sub>, T<sub>16</sub>,  
T<sub>18</sub>, T<sub>19</sub>, T<sub>21</sub>, T<sub>22</sub>, T<sub>23</sub>, T<sub>24</sub>, T<sub>29</sub>, 3./T<sub>1</sub>

C.<sup>45</sup>: 1./A<sub>1</sub>, A<sub>3</sub>, A<sub>4</sub>, A<sub>6</sub>.

**Remark:** In the future, I will express briefly and together the main sum and part sums of the assets-aspect property classification on the follow method:

For the formula  $P_{GR}^q(\mathbf{e}) = \sum_{i=1}^n q_i(\mathbf{e}_i)$  and for the formula

$P_{GR}^v(\mathbf{e}) = \sum_{i=1}^n v_i(\mathbf{e}_i)$  I will write only the follow formula:  $P = \sum_{i=1}^n A_i$ , where

$A_i$  denotes ( $i=1,2,\dots,n$ ) in the quantity or the monetary value (etc.) some part sum of asset type class of the assets-aspect property classification; and  $P = P_{GR}^q(\mathbf{e})$  and  $P = P_{GR}^v(\mathbf{e})$  also together, if the previous notations are unnecessary.

Theorem 2: If the economist has debt (other: liability or foreign capital) in the  $t$ th time point ( $t=1,2,\dots$ ), then in its gross property's capital-aspect static middle class, whose name is still foreign capital class, or rather in its any non-empty middle or final class belonging part's quantity or monetary value (or other characteristic's measure) marker main or part sum is possible only positive number<sup>46</sup> (T<sub>2</sub>).<sup>47</sup>

Let  $E_0$  denote the economist who has debt in  $t$ th time point by the condition and e.g. by the inventory. Let  $D_0$  denote debt's measure

<sup>44</sup> The enumeration after the 'P' shows that the given axiom and/or theorem in which next theorem(s) is (are) used.

<sup>45</sup> The enumeration after the 'C' shows that the given theorem, as conclusion, what and how many on premise bottoms. (That is: 'C' denotes the expression 'the theorem follows from this and from this'.)

<sup>46</sup> Here and later under the numbers, if it is not index, we understand always rational numbers.

<sup>47</sup> This theorem 2 is very important, because yet in near the past too, some theoretician of the traditional bookkeeping had that: the debit (aka: liability) is negative property (assets), what is a dangerous false statement, mainly in the education.

of  $E_0$  (that is the main sum of the static debt/liability class), aside from denoting of the  $t$ th time point.

Let us show that  $D_0 > 0$ .

Inasmuch as the economist  $E_0$  has debt, hence necessarily it has creditor by axiom  $A_9$ . Let this creditor be e.g. now the economist  $E_1$  by oneself, to who the economist  $E_0$  owes with  $D_0$ . Since  $E_1$  is creditor of  $E_0$ , hence  $E_1$  has acknowledged claim  $CL_1$  opposite the  $E_0$ . Its claim  $CL_1$  is same measure and equal with  $D_0$  ( $CL_1 = D_0$ ), by axiom  $A_{10}$ . Namely the axiom  $A_{10}$  says that: "In a given time existing debt of the debtor equal its creditor's or creditors' opposite with it with now existing total claim ( $A_{10}$ )". So a part or the whole of gross property of  $E_1$  materializes as claim  $CL_1$  in opposite  $E_0$  (by  $A_{10}$ ). That is, the follow statement is true:  $CL_1 \leq P_1$ , where  $P_1$  denotes the gross property of  $E_1$  (see: figure  $T_2$ ).

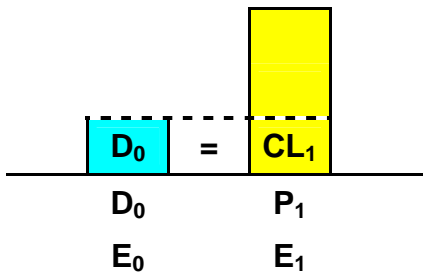

**Figure  $T_2$**

However we know in the theorem  $T_1$  that: "If the economist has property in the  $t$ th time point ( $t=1,2,\dots$ ), then in this property or rather in its any non-empty assets-aspect static property class belonging goods' quantity or monetary value (or other characteristic's measure) marker main or part sum is possible only positive number." Consequently the existing gross property  $P_1$  of  $E_1$  greater than zero, that is  $P_1 > 0$ , and this respects to any part sum of assets-aspect non-empty property class of this gross property  $P_1$ , thus this is true to claim  $CL_1$  of  $E_1$  too. That is,  $CL_1 > 0$  is also true. Since  $CL_1 > 0$  and  $CL_1 = D_0$  hence from these  $D_0 > 0$  flows directly.

By the same train of thought we can know to show that: the positivity exists to the all non-empty final classes of debt  $D_0$  belonging the part sums of types of debt too. Hence we may have:  $D_{0,1} + \dots + D_{0,j} + \dots + D_{0,N} = D_0 > 0$ , where  $D_{0,j} > 0$  is one of the part sums of the non-empty static final debt/liability (other foreign capital) class.

Q.e.d.

P.: 1./ $T_3, T_4, T_5, T_{11}, T_{12}, T_{13}, T_{14}, T_{15}, T_{21}, T_{29}$ .

C.: 1./ $A_9, A_{10}, T_1$ .

Theorem 3 (Lemma<sup>48</sup>): In the  $t$ th time point ( $t=1,2,\dots$ ) the difference of the size of property of the economist and the in with it same measure expressed size of debt of the economist may be greater or less than zero, or equal to zero ( $T_3$ ).

Let  $P$  denote the size of gross property of the economist, as the main sum of assets-aspect static classification of its gross property, in some  $t$ th time point.  $P \geq 0$  is true by  $T_1$  and  $A_2$ . Item, let  $D$  denote the size of debt (aka: liability) of the economist, as the main sum of relative base class of capital-aspect static classification of its gross property, also in the  $t$ th time point.  $D \geq 0$  is true by  $T_2$  and  $A_2$ . Additionally: the measures of  $P$  and  $D$  are same.

Let us show that  $P - D \geq 0$  in the  $t$ th time point. (We set aside from  $t$  in the notations henceforth.)

It is true that  $P > D$  or  $P = D$  or  $P < D$  by axiom  $A_8$ . Thus we can denote these together by the follow formula:  $P \geq D$ . Now if we subtract from both side of inequality  $P \geq D$  the debt  $D$ , then from this the truth of the formula  $P - D \geq 0$  and thus the truth of the 3<sup>rd</sup> theorem flow directly.

Q.e.d.

P.: 1./ $T_4$ ,  $T_{29}$ .

C.: 1./ $A_2$ ,  $A_8$ ,  $T_1$ ,  $T_2$ .

Theorem 4: The size of in the  $t$ th time point ( $t=1,2,\dots$ ) given net property (alias: equity or eigen capital), as the non-negative gross property's capital-aspect relative base class' main sum, may be whatever sign number ( $T_4$ ).

Let  $P_{NE}$  denote the size of net property of the economist in the  $t$ th time point. (E denotes the economist.) Item, let  $P$  denote the E's gross property's the size ( $P \geq 0$  by  $T_1$  and  $A_2$ ), and let  $D$  denote E's debt's size ( $D \geq 0$  by  $T_2$  and  $A_2$ ), and these are defined also in the  $t$ th time point. The measures of these three variables  $P_{NE}$ ,  $P$  and  $D$  are same.

Let us show that  $P_{NE} \geq 0$  in the  $t$ th time point. (Henceforth we set aside from  $t$  in the notations.)

We know that  $P - D \geq 0$  by the theorem  $T_3$ . But since the difference  $P - D$  is called to net property, by definition, and here it is denoted with  $P_{NE}$ , hence  $P - D = P_{NE}$ . However since  $P - D \geq 0$  and  $P - D = P_{NE}$  thus  $P_{NE} \geq 0$  is true. Q.e.d.

**Remark:** If in some  $t$ th time point  $P_{NE} = 0$ , then to this main sum  $P_{NE}$  belonging equity (other eigen capital) class  $\mathcal{C}_E$  is empty, by  $A_2$ . But if  $P_{NE} > 0$ , then  $\mathcal{C}_E$ , which the capital-aspect middle class of the property, has element(s). This/these property object(s) is/are into  $\mathcal{C}_E$ , in the  $t$ th time point. If now  $P_{NE} < 0$ , then  $\mathcal{C}_E$  has element(s) also, but this/these is/are the missing property object(s) in the  $t$ th time point; this time just hence negative  $P_{NE}$ , by the relating definition.

P.: 1./ $T_5$ .

---

<sup>48</sup> The meaning of the lemma is 'auxiliary theorem'.

C.: 1./A<sub>2</sub>, T<sub>1</sub>, T<sub>2</sub>, T<sub>3</sub>

Theorem 5: In the  $t$ th time point ( $t=1,2,\dots$ ) of two static subclass, which ones spring the non-negative gross property with capital-aspect division, the main sum of the equity class may be any sign number, till the main sum of the foreign capital may be only non-negative number, in the sum of the two main sums are non-negative (T<sub>5</sub>).

Let  $P_{GR}$ ,  $C_E$ ,  $C_F$  be three variable ( $C_E=P_{NE}$ ) in any  $t$ th time point ( $t=1,2,\dots$ ). Let  $P_{GR}$  denote, as main sum, the size of the gross property in time point  $t$ . Let  $C_E$  denote, as main sum, the size of the equity (other the eigen capital). Item, let  $C_F$  denote, as main sum, the size of the debt/liability (other the foreign capital) also in  $t$ th time point.

$P_{GR}$  and  $C_F$  is both non-negative by T<sub>1</sub>, T<sub>2</sub> and A<sub>2</sub>. We may write that

(1)  $P_{GR}-C_F=C_E$ , then after redistribution that

(2)  $P_{GR}=C_E+C_F$ .

Firstly let us show that  $C_E+C_F \geq 0$  in any  $t$ th time point.

Since  $P_{GR} \geq 0$  in any  $t$ th time point (by T<sub>1</sub>, A<sub>2</sub>), hence we may write that:

(3)  $P_{GR}=C_E+C_F \geq 0$  in any  $t$ .

Secondly let us show that  $C_E \geq 0$  and  $C_F \geq 0$ , in  $C_E+C_F \geq 0$  in any  $t$ th time point by the hypothesis and the (3).

Since  $C_E \geq 0$  and  $P_{GR}-C_F=C_E$ , so we write:

(4)  $P_{GR}-C_F=C_E \geq 0$ , that is:

(5)  $P_{GR}-C_F \geq 0$  and from this: (6)  $P_{GR} \geq C_F$ , in  $P_{GR} \geq 0$  and  $C_F \geq 0$  in any  $t$ .

We know from the axiom A<sub>8</sub> that (a)  $P_{GR} > C_F$  or (b)  $P_{GR}=C_F$  or (c)  $P_{GR} < C_F$  and both non-negative. Consequently (4), (5) and (6) is true near (3), so (a) (b) and (c) is true too, because  $P_{GR}$  and  $C_F$  has not upper bound, that is, they may be whatever great numbers, only the zero exists as their lower bound. Hence e.g. if  $P_{NE}=0$ , then  $C_F=-C_E$  (in  $C_F \geq 0$ ). This time the eigen capital (alias equity), in absolute value, same to the foreign capital (alias liability), but  $C_E \leq 0$ .

Thus it is true that in any  $t$ th time point  $C_E \geq 0$  and  $C_F \geq 0$ , in  $C_E+C_F \geq 0$ .

Q.e.d.

P.: 1./T<sub>11</sub>, T<sub>15</sub>, T<sub>29</sub>.

C.: 1./A<sub>2</sub>, A<sub>8</sub>, T<sub>1</sub>, T<sub>2</sub>, T<sub>4</sub>.

Theorem 6: In the  $t$ th time point ( $t=1,2,\dots$ ) to the static final class of the net property which named startup capital belongs part sum may be only positive number (T<sub>6</sub>).

Let  $C_{ST}$  denote the part sum of startup capital class of the net property. Let us show that  $C_{ST} > 0$ .

$C_{ST}$  shows by definition that when the economist began to manage, then how much was its invested gross property in money or in form of other asset, just as that, how much other property did it have to invest, as capital lifting, additional and eventual, or rather how much property did it have to extract, as capital cutting, from the economy.

Now let the economist invest into its economy e.g. money and a realty on the beginning of the economy. Let  $P_{ST}$  denote the size of the assets-aspect startup property.  $C_{ST}=P_{ST}$  by definition and their measures are same. But  $P_{ST}>0$  (by  $T_1$ ), thus we may write:  $C_{ST}=P_{ST}>0$ , so  $C_{ST}>0$ .

Let  $C_{ST}'$  denote the value of the modified startup capital. In case of the capital lifting let  $\Delta P_{ST}$  denote the size of the additional property and  $\Delta P_{ST}>0$  (by  $T_1$ ). Let  $\Delta C_{ST}$  denote the plus capital.  $\Delta C_{ST}=\Delta P_{ST}$  by definition and their measures are same. Since  $\Delta P_{ST}>0$  and  $\Delta C_{ST}=\Delta P_{ST}>0$  and thus  $\Delta C_{ST}>0$ . The value of the lifted startup capital  $C_{ST}'=C_{ST}+\Delta C_{ST}$ . But since  $C_{ST}>0$  and  $\Delta C_{ST}>0$  is true, thus  $C_{ST}'>0$  too.

In case of the capital cutting let  $C_{ST}'=C_{ST}-\Delta C_{ST}$ , where  $\Delta C_{ST}$  is such capital-size which equal with that part of the property with which we extract among of  $C_{ST}$  and it is less then  $C_{ST}$  but greater then zero, that is  $0<\Delta P_{ST}=\Delta C_{ST}<C_{ST}$ . Thus  $\Delta C_{ST}-\Delta C_{ST}<C_{ST}-\Delta C_{ST}$ , hence  $0<C_{ST}-\Delta C_{ST}=C_{ST}'$  and thus  $0<C_{ST}'$ .

That is true that  $C_{ST}, C_{ST}'>0$ .

Q.e.d.

P.: 1./ $T_{11}$ ,  $T_{12}$ ,  $T_{14}$ .

C.: 1./ $T_1$ .

**Theorem 7:** In the  $t$ th time point ( $t=1,2,\dots$ ) to the static final class of the net property which named reserve capital belongs part sum may be only non-negative number ( $T_7$ ).

Let  $C_R$  denote the part sum of reserve capital class of the net property. Let us show that  $C_R>0$ .

$C_R$  shows by definition that the owner(s) or other(s) when and how much other property did it/they have to invest eventual into the economy, or how much property did it/they have to extract from there, not counting the startup capital.

Now let the economist invest into its economy e.g. money and/or other asset. Let  $P_R$  denote the size of this assets-aspect additional (surplus) property. However  $C_R=P_R$  by definition and their measures are same. But  $P_R>0$  (by  $T_1$ ), so we may write:  $C_R=P_R>0$ , that is  $C_R>0$ .

We may show alike that if reserve capital is reduced, then it is also greater then zero if there is still element in the reserve capital class, or else  $C_R=0$  ( $A_2$ ).

Q.e.d.

P.: 1./ $T_7/C$ ,  $T_{11}$ ,  $T_{12}$ ,  $T_{14}$ .

C.:  $1./A_2, T_1.$

**Corollary:** From the theorem it is clear: if  $C_R > 0$  then part sums of all non-empty subclasses of reserve capital class are also positive numbers.

P.:

C.:  $1./T_7.$

**Theorem 8:** In the  $t$ th time point ( $t=1,2,\dots$ ) to static cumulated gross result class of the net property, which named static cumulated yield class, belongs part sum, as in the  $t$ th time point existing quantity or monetary value (or its other characteristic's measure) of the cumulated yield, we may express with only positive number ( $T_8$ ).

Let  $Y_C$  denote in the  $t$ th time point ( $t=1,2,\dots$ ) existing the size of the cumulated yield, which the economist realized in the interval  $(0;t]$ . Let us show that  $Y_C > 0$ .

Under the cumulated yield (value)  $Y_C$  must be understand the increment of the eigen capital (alias equity) which was obtain in interval  $(0;t]$  ( $t=1,2,\dots$ ) of economy, but not included the increment of the startup and/or reserve capital, by definition. This equity's increment may materialize in shape of any cash income or received goods or services (to barter also) or recognized claim, furthermore the property's natural increment or rather debit's release. This increment equal with the part sum  $Y_C$  of the cumulated yield class named to final class of the equity named to static relative base class in the  $t$ th time point.

Let this equity's increment materialize e.g. in shape of cash income and let  $I_M$  denote this cash income's quantity.  $Y_C = I_M$  by definition and their measures are same. We know (from  $T_1$ ) that the quantity or the monetary value of the property or its any part may be only positive number. Since this cash income is part of the property, so we may write:  $Y_C = I_M > 0$ , that is  $Y_C > 0$ .

We may show alike that if the cumulated yield materializes e.g. in other form of the property, in the aforesaid, then  $Y_C > 0$  also.

Q.e.d.

P.:  $1./T_8/C, T_{11}, T_{12}, T_{14}.$

C.:  $1./T_1.$

**Corollary:** From the theorem it is clear: if  $Y_C > 0$  then part sums of all non-empty subclasses of cumulated yield class are also positive numbers.

Q.e.d.

P.:

C.:  $1./T_8.$

**Theorem 9:** In the  $t$ th time point ( $t=1,2,\dots$ ) to the subclass of static cumulated gross result class of the net property, which named static cumulated costs class, belongs part sum, as in the  $t$ th time point existing quantity or monetary value (or its other characteristic's measure) of the cumulated costs, we may express with only negative number ( $T_9$ ).

Let  $C_C$  denote in the  $t$ th time point ( $t=1,2,\dots$ ) existing the size of cumulated costs, which sprang in the economist's economy in the interval  $(0;t]$ . Let us show that the part sum  $C_C$  of the non-empty static cumulated costs class less than zero, that is:  $C_C < 0$ .

By the definition under the cumulated costs (value) in the  $t$ th time point ( $t=1,2,\dots$ ) must be understood that decrement of the eigen capital (alias equity) which eventuated in interval  $(0;t]$  of economy, but not included the decrement of the startup and/or reserve capital. This equity's decrement, within this the increment of loss, may materialize in shape of any used of the assets, eventual payment,<sup>49</sup> given goods or services (to barter also) or issued liability, additionally the property's natural decrement or rather credit's release. This decrement equal with the part sum of the cumulated costs class named to final class of the equity named to static relative base class in the  $t$ th time point.

Let this equity's decrement materialize now e.g. in shape of eventual cash payment, which was executed for some received service. Let  $D_M$  denote this paid cash's quantity, which decreased the supply  $S'_M$  of money (by  $A_{15}$ ).  $S'_M$ , as property-part, is greater than zero by  $T_1$ , that is:  $S'_M > 0$ . Now if the cost means paying of a money-dose  $M$ , where  $0 < M \leq S'_M$ , then  $M$  must be detracted from  $S'_M$ . Consequently the cash payment  $M$ , as negative number decreases the positive sign supply  $S'_M$  of money (by  $A_{15}$ ). Thus instead of  $M$  let  $-M$  denote this cash payment, which by the definition of the cumulated costs equal to  $C_C$ , that is,  $C_C = -M$  (their measures are same). This time:  $-M < 0$ , so  $C_C = -M < 0$  and thus  $-M = C_C < 0$ .

We may show alike that if the cumulated costs materializes in other form of the property, in the aforesaid, then  $C_C < 0$  also.

Q.e.d.

P.:  $1./T_8/C, T_{10}, T_{11}, T_{12}$ .

C.:  $1./A_{15}, T_1$ .

**Corollary:** From the theorem 9 it is clear: if  $C_C < 0$  then part sums of all non-empty subclasses of cumulated costs class are also negative numbers ( $T_9/C$ ).

P.:

C.:  $T_9$ .

**Theorem 10:** If in the  $t$ th time point ( $t=1,2,\dots$ ) the cumulated or rather the current period yield less than the with it in same measure given cumulated or rather current period costs' absolute value, then the in  $t$ th time point existing cumulated or rather current period gross result's name is loss, if the yield is greater, then its name is profit, both are implicitly cumulated or rather current period ( $T_{10}$ ).

Let  $Y$  denote the measure of the cumulated or rather the current period yield just as let  $C$  denote the measure of the cumulated or rather the current period costs, item let  $|C|$  denote absolute

<sup>49</sup> All costs are expenses, sooner or later, but not all expenses (such as those incurred in acquisition of an income-generating asset) are costs.

value of  $C$ ; and finally let  $R$  denote the measure of the cumulated or rather the current period result in the  $t$ th time point ( $t=1,2,\dots$ ). (Measure of  $Y$ ,  $C$  and  $R$  is same.)

Hereafter I mention briefly only yield or cost or result without notation of the season, but these belong always to same interval and may be cumulated or rather in current period.

Now let us show that

a) if  $Y < |C|$  then name of result  $R$  is loss, while

b) if  $Y > |C|$  then name of result  $R$  is profit.

By the condition of the case a):  $Y < |C|$ . But  $Y - |C| < |C| - |C|$ , however  $|C| - |C| = 0$  and thus  $Y - |C| < 0$ . But  $C < 0$  by  $T_9$  and hence  $|C| = -C$ . Thus we may write that:  $Y - |C| = Y - (-C) = Y + C < 0$ .

Since by the definition of the cumulated or rather the current period result:  $Y + C = R$ , just as:  $Y + C < 0$ , thus  $R < 0$ . But then from these and from the relating definition it directly flows that the name of the cumulated or rather the current period result  $R < 0$  is the cumulated or rather the current period loss.

By the condition of the case b):  $Y > |C|$ . But this time it suffices if in all steps of proof of the case a) we write for the relation sign ' $<$ ' the relation sign ' $>$ '. From this promptly it flows:  $R > 0$ . But then from  $R > 0$  and from the relating definition it directly flows that the name of the cumulated or rather the current period result  $R > 0$  is the cumulated or rather the current period profit.

Q.e.d.

P.:  $1./T_{10}/C$ .

C.:  $1./T_9$ .

**Corollary:** From this theorem 10 it is already clear that in the  $t$ th time point ( $t=1,2,\dots$ ) the cumulated or rather current period result  $R$  may be any sign number ( $R \in \mathbb{R}$ ) ( $T_{10}/C$ ).

P.:

C.:  $1./T_{10}$ .

**Theorem 11:** Let the gross property or its some part be classified in the  $t$ th time point ( $t=1,2,\dots$ ) by assets- or capital-aspect. Additionally: the property changes, which ones result in this gross property or its part, let them be classified by time-aspect in the interval  $(0;t]$ . Thus in the  $t$ th time point to this static property class belonging main or rather part sum equal to the time classes of interval  $(0;t]$  belonging with sum of part sums which may be only non-negative number, except the part sum of the equity class and result class which may be any sign number, just as the part sum of the costs class which may be only non-positive number ( $T_{11}$ ).

Let  $\mathcal{C}_{ST}$  denote an assets- or capital-aspect static property class in the time-point  $t=M$  ( $t, M=1,2,\dots$ ). Just as let  $\mathcal{C}_{CH}$  denote property change class in the interval  $(0;M]$ , which resulted in the interval  $(0;M]$  by the means of property change happened in the class  $\mathcal{O}$  existing property or property hiatus in the  $M$ th time-point.

Now let  $P_M(\mathcal{C}_{ST})$  denote to the static property class  $\mathcal{C}_{ST}$  in the  $M$ th time-point belonging main or rather part sum. Additionally let  $P_{(0;M]}(\mathcal{C}_{CH})$  denote the main sum of the property change class  $\mathcal{C}_{CH}$  which expressed by same measure as  $P_M(\mathcal{C}_{ST})$ . Finally let  $I(t)$  denote

the part sum of some dynamic time class of the property changes class.

For  $A_4$  is true:  $P_{(0;M]}(\mathbf{c}_{CH}) = \sum_{t=1}^M I(t)$ . Thus the formula of the theorem 11 is the following:

$P_M(\mathbf{c}_{ST}) = P_{(0;M]}(\mathbf{c}_{CH}) = \sum_{t=1}^M I(t) \geq 0$  ( $t, M=1, 2, \dots$ ), except the case of the equity (aka: eigen capital), the result and the costs. Let us show this one.

Now then the followings are standing:

(1/a)  $P_M(\mathbf{c}_{ST}) \geq 0$  by  $T_1, T_2, T_6, T_7, T_8$  and  $A_2$  if  $\mathbf{c}_{ST}$  is not the class of the equity or the result and the costs, else

(1/b)  $P_M(\mathbf{c}_{ST}) \leq 0$  by  $T_5$  and  $T_{10}/C$  if  $\mathbf{c}_{ST}$  is the class of the equity or the result, just as

(1/c)  $P_M(\mathbf{c}_{ST}) \leq 0$  by  $T_9$  és  $A_2$  if  $\mathbf{c}_{ST}$  is the class of the costs.

Since the amount  $P_M(\mathbf{c}_{ST})$  sprang in the interval  $(0;M]$  for the algebraic sum of the property changes, hence the following is true by  $A_5$ :

$$(2) P_M(\mathbf{c}_{ST}) = P_{(0;M]}(\mathbf{c}_{CH}) = \sum_{t=1}^M I(t) \quad (t, M=1, 2, \dots).$$

But the equal value expressions may transpose, hence the (1/a), (1/b) and (1/c) inequalities and their left-side we may write thus too:

(3/a)  $P_M(\mathbf{c}_{ST}) = P_{(0;M]}(\mathbf{c}_{CH}) = \sum_{t=1}^M I(t) \geq 0$  ( $t, M=1, 2, \dots$ ), just as in the case of the equity or the result class:

(3/b)  $P_M(\mathbf{c}_{ST}) = P_{(0;M]}(\mathbf{c}_{CH}) = \sum_{t=1}^M I(t) \leq 0$  ( $t, M=1, 2, \dots$ ), additionally in the case of the costs class:

(3/c)  $P_M(\mathbf{c}_{ST}) = P_{(0;M]}(\mathbf{c}_{CH}) = \sum_{t=1}^M I(t) \leq 0$  ( $t, M=1, 2, \dots$ ), where in the case of (3/b) and (3/c) by  $T_5, T_9$  and  $T_{10}/C$  only in the relations sign is difference.

Q.e.d.

P.: 1./ $T_{12}, T_{14}, T_{18}$ ,

C.: 1./ $A_2, A_4, A_5, T_1, T_2, T_5, T_6, T_7, T_8, T_9$ .

Corollary 1: From this theorem 11 it is already clear that the main or part sum of some class of any aspect static property classification may be any sign number if the elements of the class equal to with the elements of the equity or the result class. If however the static property classification is asset-like or within the capital-like it is debt-like, then the main or part sum of this static class may be only non-negative number.

Q.e.d.

P.: 1./ $T_{12}$ .

C.: 1./ $T_{11}$ .

Corollary 2: From this theorem 11 it is already clear that to the time classes  $\mathbf{c}_{CH}(t)$  of the interval  $(0;M]$  ( $t, M=1, 2, \dots$ ) belonging from part sums  $I(t)$  squarely follows to the  $M$ th time-point belonging the value

$P_M(\mathcal{C}_{ST})$  of the static property class  $\mathcal{C}_{ST}(M)$ . However the reverse of this one is not true. But this relationship is true on the  $P_M(\mathcal{C}_{ST})$  and its part sums of the static sub class too.

Q.e.d.

P.:

C.: 1./T<sub>11</sub>.

**Theorem 12 (Lemma):** If in the t=M time-point the main or part sum of the some static property class is non-negative (or non-positive), then in the interval (0,M], in the class belonging property (property hiatus) resulting in to the property changes' first t (t=1,2,...,M) time classes belonging sum of part sums is also such (T<sub>12</sub>.L.).

Let  $\mathcal{C}_{ST}$  be a static property class by the premise in the t=M time-point (M>0 and integer) which at that time is non-empty, or empty. Let  $P_t(\mathcal{C}_{ST})=P_M(\mathcal{C}_{ST})$  to the  $\mathcal{C}_{ST}$  belonging main or part sum in the Mth time-point. Now firstly (I.): let  $P_M(\mathcal{C}_{ST})>0$  if  $\mathcal{C}_{ST}$  in the Mth is non-empty (by T<sub>1</sub>, T<sub>2</sub>, T<sub>6</sub>, T<sub>7</sub>, T<sub>8</sub>, T<sub>11</sub>/C<sub>1</sub>) then  $P_M(\mathcal{C}_{ST})=0$  if  $\mathcal{C}_{ST}$  even then is empty (by A<sub>2</sub>). With that let us express the two cases with one relation sign. Thus  $P_M(\mathcal{C}_{ST})\geq 0$ . Secondly (II.): let us analyse the theorem 12 near  $P_M(\mathcal{C}_{ST})\leq 0$  (by T<sub>9</sub>, T<sub>11</sub>/C<sub>1</sub>, A<sub>2</sub>). Only these two situations may stand by the condition.

(I.) Now let  $\mathcal{C}_{CH}$  denote to the interval (0;M] belonging property changes base class. These property changes in  $\mathcal{C}_{CH}$  were result in the  $\mathcal{C}_{ST}$ . Let  $P_M(\mathcal{C}_{CH})$  denote the main sum of the  $\mathcal{C}_{CH}$ . Now let us divide up in the interval (0;M] existing property change class  $\mathcal{C}_{CH}$  by M pieces time classes. Let I(t) denote the part sum of the tth time class (t=1,2,...,K,...,M; K,M>0 and integer). Additionally let  $P_K(\mathcal{C}_{CH})$  be to first K time classes of the property change class  $\mathcal{C}_{CH}$  belonging K pieces part sums' the sum. We may write this relationship with the follow formula:  $P_K(\mathcal{C}_{CH}) = \sum_{t=1}^K I(t)$ , where  $1 \leq K \leq M$ .

I have:

(1) If  $P_M(\mathcal{C}_{ST}) \geq 0$ , then  $P_K(\mathcal{C}_{CH}) = \sum_{t=1}^K I(t) \geq 0$ , where  $1 \leq K \leq M$ .

It is clear that in case of K=M the predicate of the theorem 12 is true by the condition and the T<sub>11</sub>. That is:

$P_M(\mathcal{C}_{ST}) = P_M(\mathcal{C}_{CH}) = \sum_{t=1}^M I(t) \geq 0$ . Hence we must demonstrate the theorem 12

only on the  $1 \leq K \leq M-1$  cases.

But I have:

(2) If  $P_M(\mathcal{C}_{ST}) \geq 0$ , then  $P_K(\mathcal{C}_{CH}) = \sum_{t=1}^K I(t) \geq 0$  is true, where  $1 \leq K \leq M-1$ .

If namely (2) is not true, then

(3) near  $P_M(\mathcal{C}_{ST}) \geq 0$   $P_K(\mathcal{C}_{CH}) = \sum_{t=1}^K I(t) < 0$ , where  $1 \leq K \leq M-1$ .

But by  $T_{11}$   $P_M(\mathbf{C}_{CH}) = \sum_{t=1}^M I(t) \geq 0$ , if  $t=1, 2, \dots, K, \dots, M-1, M$ . Thus if  $t=K$  then the follow is true:

$$(4) P_K(\mathbf{C}_{CH}) = \sum_{t=1}^K I(t) \geq 0, \text{ where } 1 \leq K \leq M-1.$$

But then thus on  $P_K(\mathbf{C}_{CH})$  we get two values:  $P_K(\mathbf{C}_{CH}) < 0$  by (3) and  $P_K(\mathbf{C}_{CH}) \geq 0$  by (4). That is  $P_K(\mathbf{C}_{CH})$  is less then zero and is not less then zero together. But this one is not possible. One statement and its contrary together may not be true. Since statement (4) correspond the confirmed to  $T_{11}$  thus the statement (3), which op-posed with  $T_{11}$ , may be only false.

(II.) It is clear that the theorem 12 easy may confirm near  $P_M(\mathbf{C}_{ST}) \leq 0$  too, only we must turn round the direction of the corresponding inequality signs.

Q.e.d.

P.:  $1./T_{12}/C, T_{14}$ .

C.:  $1./A_2, T_1, T_2, T_6, T_7, T_8, T_9, T_{11}, T_{11}/C_1$ .

Corollary: If either part sum of some cumulated part sum property classification non-negative (or non-positive) then its other part sums are also such ( $T_{12}/C$ ).

Q.e.d.

P.:

C.:  $1./T_{12}$ .

**Theorem 13:** If in  $t$ th time-point ( $t=1, 2, \dots$ ) the main or part sum of some static property class is not zero then the static property class is non-empty ( $T_{13}$ ).

Let  $P(\mathbf{C}_{ST})$  denote the main or part sum of some static property class in the  $t$ th time-point ( $t=1, 2, \dots$ ).  $P(\mathbf{C}_{ST}) \neq 0$  by the condition.

I have: if  $P(\mathbf{C}_{ST}) \neq 0$  then  $\mathbf{C}_{ST}$  is non-empty in the  $t$ th time-point. If namely  $\mathbf{C}_{ST}$  is empty then  $P(\mathbf{C}_{ST}) \neq 0$  now this one contradicts to  $A_2$ , by which: "If in a given time point some static property class is empty, if and only if its main or part sum equal to zero". Thus  $\mathbf{C}_{ST}$  may not be empty then  $P(\mathbf{C}_{ST}) \neq 0$ .

Q.e.d.

P.:

C.:  $1./A_2$ .

**Theorem 14:** Let  $I(t)$  be part sum of  $t$ th time class of to the interval  $(0; M]$  belonging ( $t, M=1, 2, \dots$ ) property changes' classification. If in the interval  $(0; M]$  occurred property changes resulted in the  $M$ th time-point non-negative sized gross property or its in some static class extant part then, if  $1 \leq t \leq M$ , any part sum  $I(t)$  may be greater then zero or equal with zero. Till if  $2 \leq t \leq M$ , then any part sum  $I(t)$  may be less then zero, provided that absolute value of  $I(t)$  is not greater then the sum of the first  $t-1$  part sums ( $T_{14}$ ).

Let  $P_{GR}(t) = P_{GR}(M)$  denote, as main or part sum, in the  $M$ th time-point existing or then already (or yet) not existing gross property's, or in its any static class extant part's the size.  $P_{GR}(M) > 0$  if the property or its part in the  $M$ th time-point exists (by  $T_1$ ,

$T_2, T_6, T_7, T_8$ ) and  $P_{GR}(M)=0$  if then this ones do not exists (by  $A_2$ ). The two expression together let  $P_{GR}(M) \geq 0$ . Additionally: let  $P_{CH}(M)$  denote this property or its part resulting in to the interval  $(0;M]$  belonging dynamic property classification's main sum (the  $I(t)$  denotes some part sum of classification).

With these notations and by  $T_1, T_2, T_6, T_7, T_8$  and  $T_{11}$  just as by  $A_2$  we may write that

$$(A) \quad P_{GR}(M) = P_{CH}(M) = \sum_{t=1}^M I(t) \geq 0.$$

Let us show that if (A) is true then the part sum of any  $K$ th time class may be the follow:

(B)  $I(K) \geq 0$  if  $1 \leq K \leq M$  or rather  $I(K)$  may be yet:

(C)  $I(K) < 0$  if  $2 \leq K \leq M$  provided that  $|I(K)| \leq P_{CH}(K-1)$  where  $P_{CH}(K-1)$  is the  $I(K)$  previous the sum of part sums of the first  $K-1$  time class, on which one the next statement is true:

$$P_{CH}(K-1) = \sum_{t=1}^{K-1} I(t) \geq 0 \text{ by } T_{12}.L.$$

The (B) do not contradicts to the follow theorems  $T_1, T_2, T_6, T_7, T_8, T_{11}$  and to the axiom  $A_2$  that is to the formula (A), where

$$P_{GR}(M) = P_{CH}(M) = \sum_{t=1}^M I(t) \geq 0. \text{ Thus (B) is true.}$$

Now yet, let us verify the part (C) of theorem.

Firstly let us postulate with the case (C) opposite that  $I(K) < 0$  if  $1 \leq K \leq M$ . But this time for example let even  $I(1) < 0$ . But then to the first time class belonging part sum of the gross property or debt or their parts is negative, now (A) is true. What is impossible because this time  $I(1) \geq 0$  is possible only by  $T_{12}.L$ .

I remark that this result corresponds therewith the expressive statement also that: If  $I(1) < 0$  is true then this one means that e.g. in case of property or debt we took something out of nothing, what is nonsense. Thus: any part sum  $I(K)$  may not be negative or rather the negativity may not begin with  $K=1$  only with  $K=2$ , provided that  $I(1) > 0$  and  $I(1) \geq |I(2)|$  if  $I(2) < 0$ .

Secondly let us postulate that the opposite of (C) the following (C') is true so:

(C')  $I(K) < 0$  if  $2 \leq K \leq M$  provided that  $|I(K)| > P_{CH}(K-1)$  holds.

But  $|I(K)| = -I(K)$  because  $I(K) < 0$ .

Thus  $|I(K)| = -I(K) > P_{CH}(K-1)$  exists in (C'). Now let us add  $I(K)$  to the both sides of  $-I(K) > P_{CH}(K-1)$ . This time we may write:

(D)  $I(K) - I(K) > P_{CH}(K-1) + I(K)$ . Thus the left side of (D) equal with 0, the right side of (D) now equal with the sum of the first  $K$  part sums that is with  $P_{CH}(K)$ .

The follow is true in point of  $P_{CH}(K)$ :

(E)  $P_{CH}(K) = \sum_{t=1}^K I(t) \geq 0$  ( $2 \leq K \leq M$ ) for  $T_{12}.L$ . Now let us write for the

right side of (D) the formula (E). Thus we get that:

(F)  $0 > P_{CH}(K-1) + I(K) = P_{CH}(K) = \sum_{t=1}^K I(t) \geq 0$  ( $2 \leq K \leq M$ ). But (F) indicates contradiction since  $0 > P_{CH}(K) = \sum_{t=1}^K I(t) \geq 0$  ( $2 \leq K \leq M$ ), that is

(G)  $0 > P_{CH}(K) \geq 0$  ( $2 \leq K \leq M$ ).

In words: the (F) and (G) indicate that  $P_{CH}(K)$  is less than zero and that it is not less than zero together, what is clear contradiction. Since, the consequence was not incorrect and we got still on contradiction, hence undoubtedly the hypothesis (C') is false. Consequently the original statement (C) is true.<sup>50</sup>

That is we demonstrated that the three statements (A) and (B) and (C) are correct and thus the theorem 14 is indeed true.

Q.e.d.

P.: 1./T<sub>14</sub>/C.

C.: 1./A<sub>2</sub>, T<sub>1</sub>, T<sub>2</sub>, T<sub>6</sub>, T<sub>7</sub>, T<sub>8</sub>, T<sub>11</sub>, T<sub>12</sub>.L.

Corollary: From this theorem 14 it is already clear that if in the interval (0;M] occurred property changes resulted in the Mth time-point a some static property class with non-positive sized main or part sum then, if  $1 \leq t \leq M$ , any part sum  $I(t)$  of this dynamic property classification may be less than zero or equal to zero. Till if  $2 \leq t \leq M$ , then any part sum  $I(t)$  may be greater than zero, provided that value of  $I(t)$  is not greater than the absolute value of sum of the first t-1 part sums (T<sub>14</sub>/C).

Q.e.d.

P.:

C.: 1./T<sub>14</sub>.

Theorem 15: With the left property or its part related quantity/value of equity or part of equity with pass of time, some automatically, tends to minus infinite (T<sub>15</sub>).

Let  $P_{GR}$  denote size of the gross property ( $P_{GR} > 0$ ; T<sub>1</sub>) and let  $C_F$  denote size of the foreign capital/debt ( $C_F > 0$ ; T<sub>2</sub>). Additionally let  $C_E$  denote size of the eigen capital/equity.  $C_E = P_{GR} - C_F \leq 0$  by definition and T<sub>5</sub>.

Let us show that  $C_E$  tends to minus infinite if the economist leaves to itself its the property or any part of the property.

---

<sup>50</sup> Naturally, (C) is verifiable the lemma without too, in essence with mathematical induction.  $I(t) = I(1)$  may not be negative, because if  $I(1) < 0$  then it means that we took something out of nothing, what is nonsense.  $I(2)$  already may be negative, but its absolute value clear may not be greater than value of  $I(1)$ . So (C) in the case  $t=2$  is true firstly. Now we assume that the statement is true in the case  $t=K-1$  and we verify on  $t=K$  ( $2 \leq K \leq M$ ). This time:

$$P_{ST}(K) = P_{CH}(K) = \sum_{t=1}^{K-1} I(t) + I(K) \geq 0 \text{ by the premise, while } I(K) < 0 \text{ also by the premise. But } \sum_{t=1}^{K-1} I(t) \geq -I(K). \text{ Additionally,}$$

since  $I(K) < 0$  hence  $|I(K)| = -I(K)$  and so  $\sum_{t=1}^{K-1} I(t) \geq |I(K)|$  holds. That is it is true that  $I(K) < 0$  may be if  $2 \leq K \leq M$ , provided

that  $\sum_{t=1}^{K-1} I(t) \geq |I(K)|$ . Q.e.d. However, the mathematical induction with use, we exit from the axiomatic system, because

this time we do not lean on its axioms and proved theorems. Therefore we cannot choose this method here.

Now by  $A_7$ , if the economist in some time-point  $t_1$  ( $t_1=1,2,\dots$ ) leaves to itself its the property or any part of it, then its size and monetary value, but leastwise monetary value (or other positive coefficient linear transformation's value), the natural and/or the social and/or the economic environment through generated economic events to impression, with the lapse of time monotonous decreases and tends to zero.

Just as by  $A_{11}$ , if the economist in the said time-point  $t_1$  leaves to itself its the property or any part of it, then its debt' measure, the natural or the social or the economic environment through generated economic events to impression, with the lapse of time monotonous increases and tends to the plus infinite.

But from the two cross monotony (by  $A_7$  and  $A_{11}$ ) consequences that with the lapse of time become single such time-point  $t_N$  ( $t_1 \leq t_N$ ) from which or after which the  $C_E = P_{GR} - C_F < 0$  and this negativity, with the lapse of time, monotonous increases, that is  $C_E$  tends to the minus infinite ( $C_E \rightarrow -\infty$ ).

(Remark: the existence of the more time-point is excluded for the two cross monotony, by  $A_7$  and  $A_{11}$ .)

Q.e.d.

P.:  $1./T_{15}/C$ .

C.:  $1./A_7, A_{11}, A_{12}, A_{13}, T_1, T_2, T_5$ .

Corollary: The material position of the economist and all factors of one change with the lapse of time in case the quits of the economy too ( $T_{15}/C$ ).

Q.e.d.

P.:  $1./T_{29}$ .

C.:  $1./T_{15}$ .

### The structural laws of the property and the property classification systems

Theorem 16:  $\sum_{x=1}^y S_x^{A_1} = \sum_{y=1}^z S_y^{A_2} = \dots = \sum_{\omega=1}^{\mu} S_{\omega}^{A_n} \geq 0$ , that is: if we classify to the interval  $(0,t]$  belonging

property changes base class and/or to the  $t$ th time-point ( $t=1,2,\dots$ ) belonging balance class of it,  $n$  ways ( $n \geq 2$ ), namely by arbitrary but differing property aspect  $A_1, A_2, \dots, A_n$ , or if we complete the property classification system with a classification by aspect  $A_{n+1}$ , then the structures of classifications of this property classification system are differing, while the main sums of it, which ones expressed by same measure, are all equal ( $T_{16}$ ).

Let  $\mathbf{A}_i$  be ( $i=1,2,\dots,n,n+1$ ) an arbitrary property classification aspect and let  $S^{\mathbf{A}_i}$  denote a part sum by some aspect  $\mathbf{A}_i$ . Additionally let us denote the structures by  $\mathbf{A}_i$  of classification of in the interval  $(0;t]$  happened property changes and/or their to  $t$ th time-point belonging balances the sum of the part sums expressing with follow formulas:

$$(1) \sum_{x=1}^v S_x^{A_1}, \sum_{y=1}^z S_y^{A_2}, \dots, \sum_{u=1}^w S_u^{A_i}, \dots, \sum_{\omega=1}^{\mu} S_{\omega}^{A_n}, \text{ ill. } \sum_{\zeta=1}^{\pi} S_{\zeta}^{A_{n+1}}$$

where  $x, y, u, \omega, \xi > 0$  and are integers. With under the (1) listed formulas symbolized structure of property classifications is all differing because by the axiom  $A_6$ : totality of given property changes or rather in a given time existing property has not two same property classifications.

I have that:

$$(2) \sum_{x=1}^v S_x^{A_1} = \sum_{y=1}^z S_y^{A_2} = \dots = \sum_{u=1}^w S_u^{A_i} = \dots = \sum_{\omega=1}^{\mu} S_{\omega}^{A_n} \geq 0 \text{ is true.}$$

Let  $S_{A_i}$  denote the main sum  $\sum_{u=1}^w S_u^{A_i}$ , that is:  $S_{A_i} = \sum_{u=1}^w S_u^{A_i}$  by  $A_4$ . Thus on all  $i$  is true:

$$(3) S_{A_1} = \sum_{x=1}^v S_x^{A_1}, S_{A_2} = \sum_{y=1}^z S_y^{A_2}, \dots, S_{A_i} = \sum_{u=1}^w S_u^{A_i}, \dots \\ \dots, S_{A_n} = \sum_{\omega=1}^{\mu} S_{\omega}^{A_n}, \text{ illette } S_{A_{n+1}} = \sum_{\zeta=1}^{\pi} S_{\zeta}^{A_{n+1}}.$$

Now we can write the (2) formulas easier too:

(4)  $S_{A_1} = S_{A_2} = \dots = S_{A_i} = \dots = S_{A_n} \geq 0$ . Let us show that this statement is true.

Firstly:

(I.) If  $n=2$  then (5)  $S_{A_1} = S_{A_2} \geq 0$ . Let us verify this statement.

Now let  $P_{GR}$  denote the main sum of dynamic classification (which is by any aspect) of in the interval  $(0; t]$  happened gross property changes. Just as let  $P'_{GR}$  denote the main sum of to the  $t$ th time-point belonging some static classification (which is by any aspect) of balances of in the interval  $(0; t]$  happened gross property changes.

$P_{GR} = P'_{GR}$  by axiom  $A_5$ , independently from it that the main sum  $P_{GR}$  is main sum of dynamic or static classification, and from it also that what property aspect of the classification.

In the  $t$ th time-point with main sum  $P_{GR}$  given size of the gross property, by  $T_1$  and  $A_2$ , is not less then zero ( $P_{GR} \geq 0$ ). However by  $A_4$  the following statements hold:  $P_{GR} = S_{A_1}$  and  $P_{GR} = S_{A_2}$ , hence  $S_{A_1} = S_{A_2} \geq 0$  is true. Thus if  $n=2$  then (5) and so (4) and (2) is true also.

(II.) Let us postulate that is true the formula on  $n$  term, see in statements (2) and (4), and let us demonstrate that with the **(n+1)**th term completed formula holds too.

So, let us complete the equality-chain in (4) from (3) taken with left side of formula  $S_{A_{n+1}} = \sum_{\zeta=1}^{\pi} S_{\zeta}^{A_{n+1}}$  ( $A_4$ ), which equal to  $P_{GR}$  and its aspect  $A_{n+1}$  and its class structure is new (by  $A_6$ ).

Let us prove that the following inequality holds:

$$(6) S_{A1}=S_{A2}=\dots=S_{Ai}=\dots=S_{An}=S_{An+1}\geq 0.$$

Now, by the premise just as  $T_1$  and  $A_4$ , the next inequality holds:  
 $V_{BR}=S_{An+1}\geq 0$ .

But  $V_{BR}=S_{An}\geq 0$  is true also by the premise just as  $T_1$  and  $A_4$ ,  $A_5$ .

However so  $S_{An}=S_{An+1}$ . But by the premise  $S_{Ai}=S_{An}\geq 0$  also is true ( $i=1,2,\dots$ ). Additionally since  $S_{Ai}=S_{An}$  and  $S_{An}=S_{An+1}$  hence on all  $i$  is true:  $S_{A1}=S_{An+1}\geq 0$  ( $i=1,2,\dots,n$ ).

Consequently the formula (6) and thus the (2) and (4) any  $n$  and  $n+1$  term in case is true.

Q.e.d.

I name this theorem the **n-aspect ( $n\geq 2$ ) structural law of the property.**<sup>51</sup>

P.: 1./ $T_{16}/C_1$ ,  $C_2$ ,  $C_3$ ,  $T_{17}$ ,  $T_{17}$ .

C.: 1./ $A_4$ ,  $A_5$ ,  $A_6$ ,  $T_1$ .

Corollary 1:  $\sum_{i=1}^n A_i=C_E+C_F\geq 0$ , that is: if we classify set of balances (that is objects of the property) of to the interval  $(0,t]$  belonging gross property changes by two differing, that is: by assets and capital aspect it is classified, then this two structures of classifications system are also different, but the in same measure expressed two main sums are equal. ( $T_{16}/C_1$ ).

Q.e.d.

P.: 1./ $T_{17}$ .

C.: 1./ $T_{16}$ .

Corollary 2:  $\sum_{i=1}^M I(t)=\sum_{i=1}^n A_i=C_E+C_F\geq 0$ , that is: if set of to the interval  $(0,t]$  belonging gross property changes by time, when the set of to the  $t$ th time-point belonging balances (that is objects of the property) by assets and capital, that is together: it is classified by three differing aspect, then the structures of classifications of this dynamic and static property classification system are different, but the in same measure expressed three main sums are equal. ( $T_{16}/C_2$ ).

Q.e.d.

P.: 1./ $T_{18}$ ,  $T_{19}$ ,  $T_{20}$ ,  $T_{21}$ .

C.: 1./ $T_{16}$ .

Corollary 3:  $T^M=A^M=C^M=\dots=X^M\geq 0$ , that is: if the set of to the interval  $(0,M]$  belonging gross property changes by time, when the set of to the  $M$ th time-point belonging balances (that is objects of the property) by assets and capital plus other aspect, that is together: it is classified by  $N$  differing ( $N\geq 3$  and integer) aspect, then the structures of classifications of this dynamic and static property classification system are different, but the in same measure expressed main sums all are equal. ( $T_{16}/C_3$ ).

Q.e.d.

P.: 1./ $T_{29}$ .

C.: 1./ $T_{16}$ .

<sup>51</sup> If we leave from this theorem just as from its proof and its all premises those words what refer on the property then this theorem is same the general bookkeeping fundamental  $n$ -aspect ( $n\geq 2$ ) structural law too.

Remark:

We may write this corollary  $T_{16}/C_3$  with mathematical notation thus too:

$$\mathbf{T}^M = \mathbf{A}^M = \mathbf{C}^M = \dots = \mathbf{X}^M \geq 0, \text{ where}$$

$$\cup \cup \cup \dots \cup$$

the different aspects: 1, 2, 3, ..., N (N and integer)

and let them symbolize the classifications with the follow formulas:

- to the interval  $(0;M]$  belonging dynamic time classification the formula  $\mathbf{T}^M = \mathbf{T}^{(0;M]} = \sum_{t=1}^M \mathbf{I}(t) \geq 0$  and ( $\mathbf{T}$  is denotes 'main sum of the classification by Time')
- to the  $M$ th time-point belonging static assets classification the  $\mathbf{A}^M = \sum_{i=1}^n \mathbf{A}_i \geq 0$  and ( $\mathbf{A}$  is denotes 'main sum of the classification by Assets')
- to the  $M$ th time-point belonging static capitals classification the  $\mathbf{C}^M = \mathbf{C}_E + \mathbf{C}_F \geq 0$  ( $\mathbf{C}$  is denotes 'main or part sum of the classification by Capitals')
- when we may denote the from previous differing ( $A_6$ )  $N$ th static classification e.g. by aspect of the creditors  $\mathbf{CR}$  (we may call: the static creditors classification) the formula  $\mathbf{X}^M = \sum_{x=1}^v \mathbf{S}_x^{CR} \geq 0$ .

I name by the formula  $\mathbf{T}^M = \mathbf{A}^M = \mathbf{C}^M = \dots = \mathbf{X}^M \geq 0$  expressed corollary the **N-aspect** ( $N \geq 3$  and integer) **dynamic and static structural law of the property**.<sup>52</sup>

Theorem 17:  $\sum_{t=1}^M \sum_{i=1}^n A_i(t) = \sum_{t=1}^M C_E(t) + C_F(t) \geq 0$ , that is, to the  $t$ th time-points ( $t=1,2,\dots,M$ ) belonging the same unit and A-C-aspect<sup>53</sup> main sums of TA-TC-aspect dynamic property classification system of the gross property and their to  $M$ th time-point summarized sums are equal ( $T_{17}$ ).

The following formula (1) holds on the main and part sums of the A-C-aspect static classification of the gross property in some  $t$ th time-point by  $T_{16}/C_1$ :

$$(1) \sum_{i=1}^n A_i = C_E + C_F \geq 0. \text{ But the under (1) size of the gross property}$$

and the equity just as the debt is algebraic sum of their by time changes according to their natures (see  $A_7, A_{11}, A_{15},$ ).

Therefore, we may sum to the all intervals  $(t-1;t]$  belonging A-C-aspect changes of the gross property.

<sup>52</sup> If we leave from this theorem just as from its all premises those words what refer on the property then this theorem is same the general bookkeeping fundamental n-aspect ( $n \geq 3$ ) dynamic and static structural law too.

<sup>53</sup> Let A-C-aspect denote hereafter briefly the following expression: 'assets-capitals-aspect'. While for example the expression TA-TC-aspect equal with the next expression 'time and assets-time and capitals-aspect'.

I have that the following formula (2) holds in view of the TA-TC-aspect dynamic classification system of changes of the gross property according to this theorem,

$$(2) \sum_{t=1}^M \sum_{i=1}^n A_i(t) = \sum_{t=1}^M C_E(t) + C_F(t) \geq 0, \text{ just as on any } t\text{th term of two}$$

sums of the equality-part of (2) the following formula

$$(3) \sum_{i=1}^n A_i(t) = C_E(t) + C_F(t) \text{ (} t=1, 2, \dots, K, \dots, M \text{) also holds (see table$$

T<sub>18</sub>.)

**4 aspect complex dynamic and static balance sheet**

		Time-assets dynamic classification										Static classification			
		1	2	3	4						5				
Assets- types	a	Times (days)										a(j)s			
		0	1	2	3	4	5	6	7	8	9				
Sheep	1	1 000	10	-10											1 000
Cow	2	2 000												-1 000	1 000
Feed	3										600				600
Claims from buyers	4	300			-200								700		800
Gold money	5				200		50	150	1 100	-600	700				1 600
<b>p(t)</b>		<b>3 300</b>	<b>10</b>	<b>-10</b>	<b>0</b>	<b>0</b>	<b>50</b>	<b>150</b>	<b>1 100</b>	<b>0</b>	<b>400</b>				<b>5 000</b>
<b>Cumulated p(t)</b>		<b>3 300</b>	<b>3 310</b>	<b>3 300</b>	<b>3 300</b>	<b>3 300</b>	<b>3 350</b>	<b>3 500</b>	<b>4 600</b>	<b>4 600</b>	<b>5 000</b>				

		Time-capitals dynamic classification										Static classification			
		1	2	3	4						5				
Capitals- types	c	Times (days)										c(j)s			
		0	1	2	3	4	5	6	7	8	9				
Cumulative result	1	2 700													2 700
Services income	2						50	150							200
Revenue	3												1 400		1 400
Wagework revenue	4								1 100						1 100
Accretion	5		10												10
Labour cost	6												-100		-100
Goods cost	7												-1 000		-1 000
Long-term liabilities	8	500				50									550
Current liabilities	9	100		-10		-50						100			140
Opener balance	10														0
<b>p(t)</b>		<b>3 300</b>	<b>10</b>	<b>-10</b>	<b>0</b>	<b>0</b>	<b>50</b>	<b>150</b>	<b>1 100</b>	<b>0</b>	<b>400</b>				<b>5 000</b>

table 18

Let us verify these two statements (2) and (3).

Firstly:

The two main sums  $\sum_{t=1}^M \sum_{i=1}^n A_i(t)$  and  $\sum_{t=1}^M C_E(t) + C_F(t)$  in (2) represent the two different classification of the gross property by the

premise and the concerning definitions just as  $A_6$ . Additionally, these main sums, one by one, equal to the main sum of the gross property by mentioned definitions. For these two reasons the formula (2) evidently is same with the general formula of  $T_{16}$  in case  $n=2$ .

Secondly:

Let us verify yet the statement (3).

If  $t=1$  then (3) is true because the (2) near  $t=1$  also is true, and this time (2) and (3) are identical.

But the formula (2) is true near  $t=K$  and  $t=K+1$  too ( $K=1,2,\dots,M$ ). However, if (2) is true near  $t=K+1$  also then the following formula (4) is true also:

$$(4) \quad A_i(K+1) + \sum_{t=1}^K \sum_{i=1}^n A_i(t) = C_E(K+1) + C_F(K+1) + \sum_{t=1}^K C_E(t) + C_F(t)$$

because the formula (4) is identical with the next equality:

$$\sum_{t=1}^{K+1} \sum_{i=1}^n A_i(t) = \sum_{t=1}^{K+1} C_E(t) + C_F(t) \text{ which is true by } T_{16} \text{ if } n=2.$$

But if (4) is true then the following formula (5) is also true:

$$(5) \quad \sum_{i=1}^n A_i(K+1) = C_E(K+1) + C_F(K+1) \quad (t=K+1=2,\dots,M), \text{ because opposite}$$

in case, if two sides of (5) would not be equal then (4) would not be true, although it proved to be true.

So (5) in case  $t=K+1$  ( $t=K+1=2,\dots,M$ ) and (3) in case  $t=K$  ( $t=K=1,2,\dots,M$ ) are true and thus the theorem is true too.

Q.e.d.

P.: 1./ $T_{17}/C$ .

C.:  $A_6, A_7, A_{11}, A_{15}, T_{16}, T_{16}/C_1$ .

I name this theorem 17 to **time-assets and time-capitals-aspect dynamic structural law of the gross property**.<sup>54</sup>

Corollary: The to the  $t$ th time-point ( $t=1,2,\dots,M$ ) same unit main sums of two arbitrary two different aspect dynamic property classifications of the gross property and to  $M$ th time-point summarized their sums are equal ( $T_{17}/C$ ).

Q.e.d.

P.:

C.:  $T_{17}$ .

I name with this corollary expressed statement the **arbitrary two-aspect dynamic structural law of the gross property**.<sup>55</sup>

<sup>54</sup> If we leave from this theorem just as from its proof and its all premises those words what refer on the property then this theorem is same the general bookkeeping fundamental  $n=2$  attribute-aspect dynamic structural law too.

<sup>55</sup> If we leave from this theorem just as from its all premises those words what refer on the property then this theorem is same the general bookkeeping fundamental  $n=2$  arbitrary attribute-aspect dynamic structural law too.

Theorem 18:  $\sum_{t=1}^M I(t) = \sum_{t=1}^M \sum_{i=1}^n J_i(t) = \sum_{t=1}^M V_S(t) + V_I(t) \geq 0$ , that is, to the  $t$ th time-points ( $t=1,2,\dots,M$ ) belonging the same unit and A-C-aspect<sup>56</sup> main sums of T-TA-TC-aspect dynamic property classification system of the gross property and their to  $M$ th time-point summarized sums are equal ( $T_{18}$ ).

Let us see the following formula:

$$(1) V_{BR}^{(M)} = \sum_{t=1}^M V_{BR}(t) = \sum_{t=1}^M I(t) \geq 0 \quad (T_1, A_2),$$

where  $V_{BR}(t) = I(t)$  ( $t=1,2,\dots,M$ ) just as  $V_{BR}(t)$  and  $I(t)$  denote the same part sums of the  $t$ th time classes. The formula (1) in turn, by definition, is a with main sum and part sums expressing mathematical formula, which represents a clear by time-aspect classification of to the interval  $(0;M]$  belonging changes of the gross property.

Let T-TA-TC-aspect denote hereafter briefly the following expression: 'time-time and assets-time and capitals-aspect'.

I have by these that the following T-TA-TC-aspect formula, which corresponds to statement of the theorem, is true:

(2)  $\sum_{t=1}^M I(t) = \sum_{t=1}^M \sum_{i=1}^n A_i(t) = \sum_{t=1}^M C_E(t) + C_F(t) \geq 0$  and the any  $t$ th terms of the sums of equalities (2) are true also (see below):

$$(3) I(t) = \sum_{i=1}^n A_i(t) = C_E(t) + C_F(t) \quad (t=1,2,\dots,K,\dots,M).$$

Let us verify these formulas (2) and (3).

Firstly: The  $\sum_{t=1}^M I(t)$  and  $\sum_{t=1}^M \sum_{i=1}^n A_i(t)$  just as  $\sum_{t=1}^M C_E(t) + C_F(t)$  all represent, one by one, different classification in this property classification system by the condition and the  $A_6$ . Additionally, these sums by the condition, one by one, are equal with the main sum of the gross property. Hence the formula (2) clearly same with the general formula of the  $T_{16}$  if  $n=3$ . Therefore this part of the theorem is true.

Secondly:

Now yet let us verify the formula (3) validity [(3)  $I(t) = \sum_{i=1}^n J_i(t) = V_S(t) + V_I(t)$  ( $t=1,2,\dots,K,\dots,M$ )].

In the formula (3) in equality  $\sum_{i=1}^n J_i(t) = V_S(t) + V_I(t)$  any  $t$  ( $t=1,2,\dots,K,\dots,M$ ) on case is true by  $T_{17}$ . However, the sum  $\sum_{i=1}^n J_i(t)$  and the sum  $V_S(t) + V_I(t)$  both algebraic sum of in the  $t$ th time class belonging property changes, or other: algebraic sum of in the interval  $(t-1;t]$  belonging property changes. Hence these are equal with the part sum  $I(t)$  too.

<sup>56</sup> Let A-C-aspect denote hereafter briefly the following expression: 'assets-capitals-aspect'. While for example the string T-TA-TC-aspect denotes the next expression 'time-time and assets-time and capitals-aspect'.

So (2) and (3) are true, thus the theorem is true too.

Q.e.d.

P.: 1./T<sub>18</sub>/C<sub>1</sub>, C<sub>2</sub>, T<sub>20</sub>.

C.: 1./A<sub>6</sub>, T<sub>16</sub>/C<sub>2</sub>.

Corollary 1: The to some  $t$ th time-point ( $t=1,2,\dots,M$ ) belonging part sum of time-aspect property classification of the gross property equal with in the same unit expressed main sum of by any other but time and another aspect property classification which main sum is also to this  $t$ th time-point belongs (T<sub>18</sub>/C<sub>1</sub>).

Q.e.d.

P.:

C.: T<sub>18</sub>.

Corollary 2: To all  $t$ th time classes ( $t=1,2,\dots,M$ ) belonging part sums of any complex dynamic property classification system of the gross property and their sums are equal (T<sub>18</sub>/C<sub>1</sub>).

Q.e.d.

P.:

C.: T<sub>18</sub>.

### The relations of the economic events and the property classification systems

Theorem 19: Any and however many economist-specific economic event also occurs this fact does not affect the validity of T-A-C-aspect<sup>57</sup> dynamic and static structural law of the gross property while this time to the economic event-coordinates corresponding to the final property class belonging part sums change to the character of the economic event(s) accordingly.

Let  $P_{GR}(t)$  denote the main sum of in the time changing gross property of the economist ( $t=1,2,\dots,M$ ). Let the next formula show in the  $t=0$  time-point inventoried gross property measure and structure:  $P_{GR}(0)=I(0)=\sum_{i=1}^n A_i=C_E+C_F \geq 0$  where the terms of the inequality are expressed by quantity or monetary value or their other positive coefficient linear transformed.

Now let us investigate the conformation of validity of T-A-C-aspect dynamic and static property structural law in the interval  $[1,M]$  occurred apropos of economic events (by  $A_{12}$ ,  $A_{13}$ ) the by T<sub>16</sub>/C<sub>2</sub> the following formula with use:

$$(1) \sum_{t=1}^M I(t) = \sum_{i=1}^n A_i = C_E + C_F \geq 0.$$

In this the  $I(t)$  denotes the part sum of  $t$ th time class of gross property changes.

Thus we must show that the validity of the inequality in (1) any and however many economist-specific economic event (by  $A_{12}$ ,  $A_{13}$ ) occurs it remains true, while this time to the economic event-coordinates corresponding to the final property class belonging part sums change to the character of the economic event(s) properly.

---

<sup>57</sup> The 'T-A-C-aspect' as abbreviation is same with the expression 'time-assets-capitals-aspect'.

By the axiom  $A_{15}$ : In some  $t$ th time point ( $t=1,2,\dots$ ) occurred apropos of economic event into the touched property classification (a) only final class' part sum increase with an amount  $\Delta X$  ( $\Delta X > 0$ ), or (b) decrease with  $\Delta X$  (to the decrease, let  $c$  denote, holds:  $c = -\Delta X < 0$ ), or (c) either final class' part sum decrease with  $\Delta X$ , while either other final class' part sum increase with the selfsame  $\Delta X$  to the  $(t-1)$ th time point compared. Other character elemental property change apropos of economic event or from other cause (by  $T_{12}$ ) is not possible.

So we must investigate only the effect of three kinds changes the by  $A_{15}$ .

We must show that any possible property change bearer economist-specific economic event does not make invalid the formula in (1). As in (a) and (b) the sign of change is only different therefore their impact can be tested altogether too. Let this one be the case (A) while let case (B) be the type (c) of the changes.

Let it denote by the (A) apropos of some economic event occurring change of gross property:

$$\Delta P_{GR} = (P_{GR} \pm x) - P_{GR} = \pm x, \text{ where clear } x > 0 \text{ for } T_1.$$

Additionally, we bear on simpler format the equity and foreign property classes with additional classification. Let  $C_{E,w}$  and  $C_{F,p}$  be to the final capital classes belonging two part sums, where the two index  $w$  and  $p$  are both positive integer. This time:

(A1)  $C_E = C_{E,1} + \dots + C_{E,w} + \dots + C_{E,k}$  ( $C_{E,w}$  is part sum of an equity class),

(A2)  $C_F = C_{F,1} + \dots + C_{F,p} + \dots + C_{F,r}$  ( $C_{F,p}$  is part sum of a debt class).

End if, for reasons of convenience, we sum the maximal values of the two indexes  $w$  and  $p$  and then for  $C_{E,w}$  and  $C_{F,p}$  we may introduce the following general capital variables:  $C_j$  where  $j=1,2,\dots,z=k+r$ .

This we write:

(A3)  $P_{GR}(t) = C_E + C_F = C_1 + \dots + C_j + \dots + C_z$ , or briefly:

$$(A4) P_{GR}(t) = C_1 + \dots + C_j + \dots + C_z = \sum_{j=1}^z C_j.$$

The formula (1) now possible transformed with the new notations so:

(2)  $\sum_{t=1}^M I(t) = \sum_{i=1}^n A_i = \sum_{j=1}^z C_j \geq 0$  which in following may detail is such:

$$(A5) I(1) + \dots + I(t) + \dots + I(M) = A_1 + \dots + A_i + \dots + A_n = C_1 + \dots + C_j + \dots + C_z \geq 0.$$

Now: by the premise, let an economic event occur in some  $t$ th time-point of some interval  $[1;M]$  and the size  $\Delta P_{GR}$  of the thus resulted property change let  $\Delta P_{GR} = \pm x$  ( $x > 0$ ;  $T_1$ ). This economic event may occur only the economist's economy activity or the natural or the social or rather the economic environment to impression (by  $A_{12}$ ). And let this event touch for example the assets  $i$ th class, that is its the part sum  $A_i$  ( $A_i \pm x$ ). This time the T-A-C-aspect main

sums of this gross property must agree with each other by  $A_4$  and  $T_{16}/C_2$ . **But these main sums only then may be equal if the sides of equality-part in (3) increase with same sum or rather if those decrease with same sum. Or other: if the part sum  $I(t)$  of a time-type and the part sum  $A_i$  of a asset-type just as the part sum  $C_j$  of a capital-type change all at once by same measure and sign.** (Or else  $A_4$  and  $T_{16}/C_2$  would be false, in turn both are true.)

Now let  $C_j$  be so the changing part sum of the capital-type and let  $I(t)$  be the changing part sum of the time-type. Thus really the equality-inequality will not invalid only the corresponding three part sums change. So the formula in (A5) thus forms:

$$(A6) \quad I(1)+\dots+\underline{[I(t)\pm x]}+\dots+I(M)=A_1+\dots+\underline{(A_i\pm x)}+\dots+A_n=C_1+\dots+\underline{(C_j\pm x)}+\dots+C_z\geq 0. \quad ^{58}$$

Thus the validity of the equality-inequality spite of the property change  $\Delta V_{BR}=\pm x$  ( $x>0$ ) remained because all three aspect main sums changed identically with value  $\pm x$ . We may show this fact underlined the  $\pm x$  below:

$$(A7) \quad \underline{\pm x} + \sum_{t=1}^M I(t) = \underline{\pm x} + \sum_{i=1}^n A_i = \underline{\pm x} + \sum_{j=1}^z C_j \geq 0.$$

Naturally, the property change just therefore happened because by premise the economic event may have occurred, that is, **that was not an impossible economic event** by definition.

Namely, by the event coordinate triple  $\langle t, i, j \rangle$ ,<sup>59</sup> the part sum of the touched property classes should not change sign if it was not possible about character of the property class or the economic event. The asset-aspect part sum  $A_i$  may be zero but may not be negative because we may not took something out of nothing; namely the opposite would be nonsense. (For example: if there is not a penny nor in the checkout then the poor cashier has not to give thereof nothing; the opposite would be nonsense.)

While if  $C_j$  is the part sum of the costs class then it may be zero but may not be positive because then the property such decrease for cost that increase; or other: then the property such decrease for cost that the cost is yield by definitions. But all these are nonsense. (For example: if the part sum  $C_j$  of the costs class greater then zero then this means that the elements of the costs class that is the missing (the lost) assets become existing assets, or other: the word 'none' means that 'there is a'. But clear this is nonsense.)

We exploit that  $\Delta P_{GR}=\pm x$  ( $x>0$  for  $T_1$ ) can be any frequent and any large increase or decrease, near the foregoing non-negativity or rather non-positivity limit, because we do not define the size and the frequency of change  $\Delta P_{GR}=\pm x$ . We exploit also that  $t$  may be any time-point in the interval  $[1;M]$  and  $M$  may be any large integer.

<sup>58</sup> The underlined part sums are those part sums of the final classes which ones apropos of some economic event occurring change by the character of the event. I denote hereafter also with underline what is suggested for the respect.

<sup>59</sup> Now the event coordinates, for simplicity, denote only place of the change, here exceptionally included the coordinate  $t$ th of time class too, but their character they do not denote.

Additionally, we exploit also that  $\Delta P_{GR}=\pm x$  may be added to any  $I(t)$  and to any  $A_i$  ( $i=1,2,\dots,n$ ) or rather to any  $C_j$  ( $j=1,2,\dots,z$ ), provided that the economic event coordinate triple  $\langle t,i,j \rangle$  is realistic by definition.<sup>60</sup>

On the basis of these we can see that any number of such type and arbitrary economic event may occur and cause arbitrary size property change  $\Delta P_{GR}=\pm x$  ( $x>0$ ) this one does not void the formula (2). With this we verify the theorem on the case (A).

Now we verify the theorem on the case (B) too. Let us go from the formula (A5) again. But near the general element  $A_i$  among those let us do the other general element  $A_k$  too (where  $1\leq i,k\leq n$  and  $i\neq k$ , provided that  $\langle i,k \rangle$ <sup>61</sup> economic event coordinates are realistic):

$$(B1) \quad P_{GR}(M)=I(1)+\dots+I(t)+\dots+I(M)=A_1+\dots+\underline{A_i}+\dots+\underline{A_k}+\dots+A_n=C_1+\dots+C_j+\dots+C_z\geq 0.$$

Firstly, let them change those part sums which ones belong to the apropos of in  $t$ th time-point occurred economic events touched A-aspect final classes. Let them change with a value  $x>0$  by part (c) of the axiom  $A_{15}$ .

If this resulting in change economic event occurred and let us suppose that in the  $t$ th time-point the part sum  $A_k$  of an asset-types decrease with  $x$ , that is:  $A'_k=A_k-x\geq 0$ , while an part sum  $A_i$  of an other asset-types increase with  $x$ , that is:  $A'_i=A_i+x\geq 0$  (provided that economic event coordinates  $\langle i,k \rangle$  are realistic). This time we write:

$$A'_i+A'_k=(A_i+x)+(A_k-x)=(x-x)+A_i+A_k=0+A_i+A_k=A_i+A_k.$$

So the sum of part sums of the  $i$ th and  $k$ th assets classes did not change ( $A'_i+A'_k=A_i+A_k$ ) because the opposed changes compensated each other, namely  $x-x=0$ , that is in this case, in total, change is not. Consequently this time the main sum of the assets classification also can not change for  $A_4$ .

But this time the part sum  $I(t)$  of to the  $t$ th time-point belonging interval  $(t-1;t]$  that is time class such change that at once increase and decrease also with  $x$ , so in truth it is not change.

That is the formula (B1) will be thus:

$$(B2) \quad P_{GR}(M)=I(1)+\dots+\underline{[I(t)+x-x]}+\dots+I(M)= \\ =A_1+\dots+\underline{(A_i+x)}+\dots+\underline{(A_k-x)}+\dots+A_n=C_1+\dots+C_j+\dots+C_z\geq 0,$$

or other: since  $x-x=0$ , hence

$$\underline{I(t)+x-x}=I(t)+0=I(t), \text{ that is}$$

$$(B3) \quad P_{GR}(M)=I(1)+\dots+\underline{I(t)}+\dots+I(M)= \\ =A_1+\dots+\underline{A'_i}+\dots+\underline{A'_k}+\dots+A_n=C_1+\dots+C_j+\dots+C_z\geq 0,$$

where  $A'_i=A_i+x$  and  $A'_k=A_k-x$  are the new values of the part sums  $A_i$  and  $A_k$  ( $1\leq i,k\leq n$ ;  $i\neq k$ ; provided that the economic event coordinates

<sup>60</sup>The such event coordinate n-tuple is rational (other realistic) which some economist-specific economic events apropos of resulting in the economist's property classification system signs them and only them the property classes, completely, whose the part sum must change by the economic event's character and content.

<sup>61</sup> See the previous foot-note.

$\langle i,k \rangle$  are realistic). If we regroup the terms  $+x$  and  $-x$  on one place then we can exemplify the cause of unchanged of the main sum:

$$(B4) \quad P_{GR}(M) = \sum_{t=1}^M I(t) = \left( \sum_{i=1}^n A_i \right) + \mathbf{x} - \mathbf{x} = \sum_{i=1}^n A_i = \sum_{j=1}^z C_j \geq 0,$$

since  $x-x=0$ , and  $\left( \sum_{i=1}^n A_i \right) + \mathbf{x} - \mathbf{x} = \left( \sum_{i=1}^n A_i \right) + \mathbf{0} = \sum_{i=1}^n A_i$ .

The T and A and C-aspect main sums, in the equality-inequality system (2) and (B1), did not change despite the size  $x>0$  and assets-aspect structural-change.

To verify this theorem we exploit that this structural change can be any frequent and that the value  $x$  ( $x>0$ ) of the structural change can be any large, near the foregoing non-negativity limit, because we do not define the size and the frequency of change  $x$ . We exploit also that  $t$  may be any time-point in the interval  $[1;M]$  and  $M$  may be any large integer. Additionally, we exploit that  $x$  may be added to any  $A_i$  and may be deductible from any  $A_k$  ( $i,k=1,2,\dots,n$ ; but  $i \neq k$ ), provided that the economic event coordinate pair  $\langle i,k \rangle$  is realistic by definition.<sup>62</sup>

We may show on analogous method that the formula (2) holds then also if the structural property change  $x>0$  occurred on the capital classes, thus:

$$(B5) \quad P_{GR}(M) = \sum_{t=1}^M I(t) = \sum_{i=1}^n A_i = C_1 + \dots + \underline{(C_j + \mathbf{x})} + \dots + \underline{(C_h - \mathbf{x})} + \dots + C_z = \left( \sum_{j=1}^z C_j \right) + \mathbf{x} - \mathbf{x} \geq 0,$$

[where ( $1 \leq j, h \leq z$ ;  $j \neq h$ ), provided that the pair  $\langle j, h \rangle$  is realistic) or rather then also if the structural property change  $x>0$  occurred only on the time classes, although this latter may not be valid economic event. Here it also holds:

$$(B6) \quad V_{BR} = I(1) + \dots + \underline{[I(t) + \mathbf{x}]} + \dots + \underline{[I(u) - \mathbf{x}]} + \dots + I(M) = \left[ \sum_{t=1}^M I(t) \right] + \mathbf{x} - \mathbf{x} = \\ = \left[ \sum_{t=1}^M I(t) \right] + \mathbf{0} = \sum_{t=1}^M I(t) = \sum_{i=1}^n A_i = \sum_{j=1}^z C_j \geq 0$$

where ( $1 \leq t, u \leq M$ ;  $t \neq u$ ), provided that the coordinate pair  $\langle t, u \rangle$  is realistic.

With this we verify the theorem on the case (B) too.

Since the (A) and (B) are true hence the theorem 19 is also true.

Q.e.d.

P.: 1./T<sub>19</sub>/C<sub>1</sub>, C<sub>2</sub>; T<sub>21</sub>.

C.: 1./A<sub>2</sub>, A<sub>4</sub>, A<sub>12</sub>, A<sub>13</sub>, A<sub>14</sub>, A<sub>15</sub>, T<sub>1</sub>, T<sub>16</sub>/C<sub>2</sub>.

<sup>62</sup>The such event coordinate n-tuple is rational (other realistic) which some economist-specific economic events apropos of resulting in the economist's property classification system signs them and only them the property classes, completely, whose the part sum must change by the economic event's character and content.

Corollary 1: Absolute or relative main sum of any property classification is covariant (it changes same way) apropos of economic event occurring in point of increase or decrease of its part sum, while invariant in point of compensatory (an opposite sign but equal in size) changes of its two part sums.

$$P.: 1./T_{28}, 2./T_8.$$

$$C.: 1./T_{19}.$$

Corollary 2: Part sum of any property classification is invariant apropos of the economic event changing in point of its other part sum(s).

$$P.:$$

$$C.: T_{19}.$$

Theorem 20: Any and however many economist-specific economic event also occurs this fact does not affect the validity of T-TA-TC-aspect<sup>63</sup> dynamic structural law of the gross property while this time to the economic event-coordinates corresponding to the final property class belonging part sums change to the character of the economic event(s) accordingly.

If we make the variables  $A_i, C_E, C_F$  of the formula  $\sum_{t=1}^M I(t) = \sum_{i=1}^n A_i = C_E + C_F \geq 0$  of  $T_{16}/C_2$  into dependent from  $t$ , when to all  $t$  the interval  $(t-1;t]$  and, by definition, balance  $I(t)$  of in the interval  $(t-1;t]$  occurred property changes belongs, then we get the following formula-line:

t) tth formula

$$1) I(1) = \sum_{i=1}^n A_i(1) = C_E(1) + C_F(1),$$

$$2) I(2) = \sum_{i=1}^n A_i(2) = C_E(2) + C_F(2),$$

.

$$t) I(t) = \sum_{i=1}^n A_i(t) = C_E(t) + C_F(t),$$

.

$$M) I(M) = \sum_{i=1}^n A_i(M) = C_E(M) + C_F(M) \text{ [sf. formula (3) in } T_{18}\text{]}.$$

If we summarize the corresponding terms of formulas then we get the formula (2) of theorem  $T_{18}$  which is verified [let us denote now with (A)]:

$$(A) \sum_{t=1}^M I(t) = \sum_{t=1}^M \sum_{i=1}^n A_i(t) = \sum_{t=1}^M C_E(t) + C_F(t) \geq 0.$$

Now we must show that any and however many (but it is not impossible) economist-specific economic event also occurs, this fact does not affect the validity of T-TA-TC-aspect dynamic structural law of with the formula (A) represented gross property while this time to the (realistic) economic event-coordinates corresponding

<sup>63</sup> The 'T-TA-TC-aspect' as abbreviation is same with the expression 'time- time and assets-time and capitals-aspect'.

to the final property class belonging part sums change to the character of the economic event(s) accordingly.

But  $\sum_{t=1}^M \sum_{i=1}^n \mathbf{A}_i(t) = \sum_{i=1}^n \mathbf{A}_i$  and  $\sum_{t=1}^M \mathbf{C}_E(t) + \mathbf{C}_F(t) = \mathbf{C}_E + \mathbf{C}_F = \sum_{j=1}^z \mathbf{C}_j$  if we summarize

firstly only by time (by  $t$ ) the changes of the asset-types and capital-types while by  $i$  and  $j$  we don't. But this time formula (A) is equivalent with formula (B):

(B)  $\sum_{t=1}^M \mathbf{I}(t) = \sum_{i=1}^n \mathbf{A}_i = \mathbf{C}_E(t) + \mathbf{C}_F(t) = \sum_{j=1}^z \mathbf{C}_j \geq \mathbf{0}$ . However (B) is equivalent

with the formula  $\sum_{t=1}^M \mathbf{I}(t) = \sum_{i=1}^n \mathbf{A}_i = \mathbf{C}_E(t) + \mathbf{C}_F(t) \geq \mathbf{0}$  of theorem T<sub>19</sub>. But the

statement of T<sub>19</sub> is same with the statement of this theorem and T<sub>19</sub> is already proofed. Consequently this theorem is true too.

Q.e.d.

P.: 1./T<sub>20</sub>/C<sub>1</sub>, C<sub>2</sub>, C<sub>3</sub>, C<sub>4</sub>, C<sub>5</sub>, C<sub>6</sub>, C<sub>7</sub>.

C.: 1./T<sub>16</sub>/C<sub>2</sub>, T<sub>18</sub>, T<sub>19</sub>.

Corollary 1: The material position of the economist and its all factors apropos of economic-specific economic events in the time change.

P.: 1./T<sub>29</sub>.

C.: 1./T<sub>20</sub>.

Corollary 2: The classifications of with the formula  $\mathbf{T}=\mathbf{A}=\mathbf{C} \geq \mathbf{0}$  represented property classification system independent each from the other regarding on the only structural property changes.

P.:

C.: 1./T<sub>20</sub>.

Corollary 3: In the classifications of with the formula  $\mathbf{T}=\mathbf{A}=\mathbf{C} \geq \mathbf{0}$  represented property classification system, by the characteristic of the system, if the property increase or decrease then always 3 part sums change, one in the T and one in the A and one in the C-aspect classification, while if only the structure of some classification change then always 2 part sums change but only in T or only in A or only in F-aspect classification.

P.:

C.: T<sub>20</sub>.

**Corollary 4:** In the with formula  $\mathbf{T}=\mathbf{A}=\mathbf{C}=\dots=\mathbf{X} \geq \mathbf{0}$  represented N aspect ( $N \geq 3$  and integer) property classification system, by the characteristic of the system, if the property increase or decrease then always N part sums change, but in a classification only one, while if only some classification structure changes when any classification is independent from the others, then always 2 part sums change in the either classification. If in the system there are yet additional non-independent K ( $1 \leq K \leq N-3$  and integer) property classification then at the most  $2K+2$  part sums changes in all.

P.:

C.: T<sub>20</sub>.

Corollary 5: Aside from the time-aspect, in with the formula  $\mathbf{A}=\mathbf{C} \geq \mathbf{0}$  represented property classification system, by the characteristic of the system, apropos of any economic event always only 2, to the A and/or the C property classification belonging, part sums change, if the property soever changes too.

P.:

C.: T<sub>20</sub>.

Corollary 6: The structural law of with the formula  $T=A=C=\dots=X=0$  represented explicit N-fold ( $N \geq 3$  and integer) dynamic and static or with the formula  $TA=TC=\dots=0$  represented implicit N-fold ( $N \geq 2$ ) dynamic property classification system will hold without the property and debt beginner economist in case ( $P_{GR}=0$  and  $C_F=0$ ), just as if the economist has only debt ( $P_{GR}=0$  and  $C_F=D > 0$  és  $C_E=-D < 0$  and  $C=C_E+C_F=0$ ), any and however many (but it is not impossible) economist-specific economic event occurs.

P.:  $2./T_2$ .

C.:  $1./T_{20}$ .

### The law of the natural property classification and the natural property classes

Corollárium 7: In the  $t$ th time-points ( $t=1,2,\dots,M$ ) occurring economist-specific economic events  $e_i(t)$  [ $i=1,2,\dots,n$ ] gradually and by natural chronology build up and in all  $t$ th time-points clearly define the property classification system of the economist. In all  $t$ th time-point of this natural process those part sums which ones correspond the character and coordinates of the events  $e_i(t)$  change, that is, increase and/or decrease. This one happens then also if these changes are recorded and then also if they are not; and then also if coordinates of these events yet only can be inferable from the dates of time-point and name (description) of the economic events.

P.:

C.:  $T_{20}$ .

I name this theorem  $T_{20}/C_7$  to the law of the natural property classification, while the sprung classes to the natural property classes.

### Complete and incomplete property classification systems

Theorem 21: With the formula  $T=A=C \geq 0$  represented explicit N-fold ( $N=3$ ) property classification system of in the interval  $(0,M]$  changing gross property is complete system ( $T_{21}$ ).

By the respecting definition: I name to *complete a property classification system* if it is satisfactorily informative and closed in point of the economist-specific economic events.

We must show that with the formula

$$(1) \sum_{t=1}^M I(t) = \sum_{i=1}^n A_i = C_E + C_F \geq 0 \quad (\text{by } T_{16}/C_2)$$

represented property classification system satisfactorily informative and closed in point of the economist-specific economic events, that is, complete system.

(A) Firstly let us show that with the formula (1) symbolized property classification system is satisfactorily informative. This one holds if the formula (1) which represents the property classification system shows the economist's material position in a given time and at least the changes of its gross property to this time by the time-aspect property classification, per definiendum.

But under the *economist's material position* I understand the size of the gross and net property just as liability (aka: foreign property or all sorts of debt), at a given time; additionally structures of its property's classes and part sums.

In the formula (1) at the  $M$ th time-point summed gross property  $P_{GR} \geq 0$  ( $T_1, A_2$ ) performs with its assets ( $\sum_{i=1}^n A_i$ ) and capitals ( $C_E + C_F$ ) aspect main sums [see the following formula (2)]:

$$(2) P_{GR} = \sum_{i=1}^n A_i = C_E + C_F \geq 0.$$

Additionally, in (2) the equity (3)  $C_E \leq 0$  (by  $T_5$ ) also performs, just as the debt (foreign capital) (4)  $C_E \geq 0$  (by  $T_2, A_2$ ) too; and we can see the structures of these also, as:

$$(5) P_{GR} = \sum_{i=1}^n A_i = C_E + C_F = A_1 + \dots + A_i + \dots + A_n = C_E + C_F \geq 0.$$

Thus the formula (1) shows the economist's material position in the  $M$ th time-point, and its first term shows the changes of the gross property to the  $M$ th time-point in the interval  $(0; M]$ ; see below the formula (6):

$$(6) P_{GR} = \sum_{t=1}^M I(t) \geq 0.$$

So, with the formula (1) represented property classification system is really satisfactorily informative by the formulas (2), (3), (4), (5) and (6).

(B) Now yet we must show that with the formula (1) symbolized property classification system is closed in point of the economist-specific economic events.

I name to closed the economist's property classification system in point of the economist-specific economic events, if and only if any so economic event results there are such part sums in the property classification system which correspond to character of event and change by the content of event, per definiendum.

By the proved theorem  $T_{19}$ : Any and however many economist-specific economic event also occurs this fact does not affect the validity of T-A-C-aspect<sup>64</sup> dynamic and static structural law of the gross property while this time to the economic event-coordinates corresponding to the final property class belonging part sums change to the character of the economic event(s) accordingly. This law is represented with the following (T) formula:

$$(T) P_{GR} = \sum_{t=1}^M I(t) = \sum_{i=1}^n A_i = C_E + C_F \geq 0 \text{ (by } T_{19}\text{)}.$$

The formula (T) is same with the formula (1), consequently with the formula (1) represented property classification system is closed in point of the economist-specific economic events.

So, we showed that with the formula (1) represented property classification system is satisfactorily informative (by A) and closed in point of the economist-specific economic events (by B), that is, complete system.

Q.e.d.

---

<sup>64</sup> The 'T-A-C-aspect' as abbreviation is same with the expression 'time-assets-capitals-aspect'.

P. : 1. / T<sub>21</sub> / C<sub>1</sub>, C<sub>2</sub>, C<sub>3</sub>, C<sub>4</sub>, C<sub>5</sub>; T<sub>23</sub>, T<sub>24</sub>, T<sub>28</sub>.  
 C. : 1. / A<sub>2</sub>, T<sub>1</sub>, T<sub>2</sub>, T<sub>16</sub> / C<sub>2</sub>, T<sub>19</sub>.

Corollary 1: With the formula  $T=A=C=\dots=X \geq 0$  represented explicit N-fold ( $N \geq 3$ ) property classification system of the gross property is complete.

Q. e. d.

P. : 1. / T<sub>23</sub>, T<sub>24</sub>, T<sub>25</sub>.

C. : 1. / T<sub>21</sub>.

Corollary 2: With the formula  $TA=TC=\dots=TX \geq 0$  represented implicit N-fold ( $N \geq 2$ ) property classification system of the gross property is complete.

Q. e. d.

P. : 1. / T<sub>23</sub>, T<sub>24</sub>, T<sub>25</sub>, T<sub>26</sub>, T<sub>28</sub>.

C. : 1. / T<sub>21</sub>.

Corollary 3: If the classification system of the gross property consists (possibly near other static property classifications) only from T, or A, or C, or A and C, or T and A, or T and C-aspect property classification, or it does not contain one of these nor, then such property classification system incomplete, although with the formula  $A=C \geq 0$  represented property classification system is closed in point of the economist-specific economic events.

Q. e. d.

P. : 1. / T<sub>26</sub>, T<sub>28</sub>.

C. : 1. / T<sub>21</sub>.

Corollary 4: The time-, asset- and capital-aspect and by T-A-C-aspect property classification is immanent feature other attribute of the property classification.

Q. e. d.

P. :

C. : T<sub>21</sub>.

Corollary 5: The maximal number of the authoritative property-aspects is n, and  $3 < n < X(t, A)$ , where X is natural number; its size is unknown and the value of the upper limit depend from the t time-point (t now is expressed in calendar year) and from the economic profile of the economist, just as from size and complexity of its economy, to which we may characterize the structure and main sum ( $A = \sum a_i$ ) of assets.

Q. e. d.

P. :

C. : T<sub>21</sub>.

Theorem 22: With the formula  $T^M = A^M = C^M \geq 0$  or the  $A^M = C^M \geq 0$  represented<sup>65</sup> property classification system, which shows in cash-flow aspect from the gross property only the money property, is incomplete.

Let it represent the explicit N-fold ( $N=3$ ) property classification system of the gross property [ $P_{GR} \geq 0$  (T<sub>1</sub>, A<sub>2</sub>)] the formula

$$P_{GR} = \sum_{t=1}^M I(t) = \sum_{i=1}^n A_i = C_E + C_F \geq 0. \text{ This system is complete (by } T_{21}\text{).}$$

<sup>65</sup> Here the meaning of the upper index M is 'Money'.

Let  $P_{GR}^M$  denote from the size of the gross property the size of the money property  $P_{GR}^M \geq 0$  ( $T_1, A_2$ ), while the size of the non-money property  $P_{GR}^N \geq 0$  ( $T_1, A_2$ )<sup>66</sup>.

This time clearly  $P_{GR} = P_{GR}^M + P_{GR}^N = \sum_{t=1}^M I(t) = \sum_{i=1}^n A_i = C_E + C_F \geq 0$ , where

$$(M) \quad P_{GR}^M = \sum_{t=1}^M I^M(t) = \sum_{i=1}^n A_i^M = C_E^M + C_F^M \geq 0 \quad \text{and}$$

$$(N) \quad P_{GR}^N = \sum_{t=1}^M I^N(t) = \sum_{i=1}^n A_i^N = C_E^N + C_F^N \geq 0.$$

Let us investigate with the formula  $T^M = A^M = C^M \geq 0$  represented property classification system of the money property.

Let us suppose that with the formula

$$(M) \quad P_{GR}^M = \sum_{t=1}^M I^M(t) = \sum_{i=1}^n A_i^M = C_E^M + C_F^M \geq 0 \quad \text{represented property classification system is **complete**.$$

Let us attempt to prove this statement.

(A) The complete property classification system is satisfactorily informative and closed in point of the economist-specific economic events, by definition. But  $P_{GR}^M$  is not same the size of the gross property, because such economic event is always in line of the economist-specific economic events which does not touch the economist's monetary instruments or its other money property (by  $A_{16}$ ) only other part of the property. Thus the effect of such economic event can not show with the formula  $T^M = A^M = C^M \geq 0$  represented in property classification system, in which there are not to this event corresponding final classes. For this it is true that:

$P_{GR} > P_{GR}^M$ ,  $C_E > C_E^M$ ,  $C_F > C_F^M$ ; that is:  $P_{GR}^M$ ,  $C_E^M$ ,  $C_F^M$  do not contain the total property, the total equity or rather the total debt/foreign capital. Namely the sums of the non-money property and its sources miss from these. Consequently,  $P_{GR}^M$ ,  $C_E^M$ ,  $C_F^M$  can not inform us on the non-money property ( $P_{GR}^N$ ), on its equity ( $C_E^N$ ) and its foreign capitals ( $C_F^N$ ). Hence the property classification system by (M) **can not be complete**.

(B) Additionally,  $P_{GR} > \sum_{t=1}^M I^M(t)$  also clearly holds, because  $\sum_{t=1}^M I^M(t)$  shows **only** the conformation of the gross money property, but the conformation of the non-money property does **not** ( $A_{16}$ ). But we had that with the formula  $T^M = A^M = C^M \geq 0$  represented property classification system is complete, that is: it inform on the gross property, however all this is not true. So we received a contradiction. Consequently, to the (M) belonging statement is false but the opposite of it is true.

Thus we proved in the parts of (A) and (B) that with the formula (M) represented property classification system is **incomplete**.

<sup>66</sup> Here the meaning of the upper index N is 'Non-money'.

(C) Now we can show also that with the formula (M) represented property classification system is not closed in point of the economist-specific economic events. Namely it is not able to show the effect of economic events that change the non-money property's main sum and/or its part sums, since there is not single final class nor in the  $T^M=A^M=C^M \geq 0$  represented property classification system with the  $T^N=A^N=C^N \geq 0$  represented system's from part sums. However, such economic event is always in line of the economist-specific economic events; this does not touch the economist's monetary instruments or other: its other money property (by  $A_{16}$ ) only other part of the gross property. But effect of this clearly does not appear in by (M) property classification system. Consequently, such system does not satisfy the other condition of the completeness nor, that is, it is not closed in point of the economist-specific economic events. This system therefore is not complete this time nor.

(D) Finally: with (M2)  $P_{GR}^M = \sum_{i=1}^n A_i^M = C_E^M + C_F^M \geq 0$  formula represented property classification system incomplete for (A) and (C) too, but it is incompleteness of (M2) yet that by time change of the money property it does not show.

Thus we verified by (A), (B), (C) and (D) that: With the formula  $T^M=A^M=C^M \geq 0$  or the  $A^M=C^M \geq 0$  represented property classification system, which shows by cash-flow aspect from the gross property only the money property, is incomplete.

Q.e.d.

P.:

C.:  $1./A_2, A_{16}, T_1, T_{21}$ .

**Theorem 23:** If the property classification system of the gross property is complete, is therein time, assets and capitals classification.

The property classification system of the gross property denoted  $P_{GR} [P_{GR} \geq 0 (T_1, A_2)]$  is complete by the condition. Now let us suppose that (H) is not therein time, assets and capitals classification.

But this hypothesis (H) contradict the already proved to theorems  $T_{21}, T_{21}/C_1$  and  $T_{21}/C_2$  that after in a complete system is time, assets and capitals classification. Thus the statement (H) is false; consequently the theorem 23 is true.

Q.e.d.

P.:

C.:  $A_2, T_1, T_{21}, T_{21}/C_1, T_{21}/C_2$ .

**Theorem 24:** If the property classification system of the gross property is complete, then it is closed in point of the economist-specific economic events.

The property classification system of the gross property denoted  $P_{GR} [P_{GR} \geq 0 (T_1, A_2)]$  is complete by the condition. Now let us suppose that (H) it is not closed in point of the economist-specific economic events.

But this hypothesis (H) contradict the already proved to theorems  $T_{21}$ ,  $T_{21}/C_1$  and  $T_{21}/C_2$  that after a complete system is closed in point of the economist-specific economic events.

Thus the statement (H) is false; consequently the theorem 24 is true.

Q.e.d.

P.:

C.:  $A_2, T_1, T_{21}, T_{21}/C_1, T_{21}/C_2$ .

**Theorem 25:** The N-pan ( $N \geq 2$ ) balance sheet of the gross property is complete system.

With the formula  $T^{(M)} = A^{(M)} = C^{(M)} = \dots = X^{(M)} \geq 0$  represented explicit N-fold ( $N \geq 3$ ) or rather with the formula  $TA^{(M)} = TC^{(M)} = \dots = TX^{(M)} \geq 0$  represented implicit N-fold ( $N \geq 2$ ) property classification system of the gross property is complete [by  $T_{21}/C_1, T_{21}/C_2$ ].

Now by the relating definition: we name to N-pan or other to N-fold balance sheet ( $N \geq 2$ ) the gross property's implicit N-fold/N-entry ( $N \geq 2$ ) or explicit N-fold/N-entry ( $N \geq 3$ ) property classification system (in some  $M$ th time-point). Thus by this definition the N-pan ( $N \geq 2$ ) balance sheet of the gross property is explicit or implicit N-fold/N-entry ( $N \geq 2$ ) property classification system, and as such is complete system.

Q.e.d.

P.:

C.:  $T_{21}/C_1, T_{21}/C_2$ .

**Theorem 26:** If a property classification system is complete, then it is an explicit N-fold ( $N \geq 3$ ) system, and at least a dynamic T, a static A and a static F property classification perform between its classifications, or it is the implicit N-fold ( $N \geq 2$ ) system, and at least a dynamic TA and a dynamic TC complex property classification perform between its classifications.

Let  $S$  denote a property classification system, and  $N$  the number of its aspects; additionally let them denote the dynamic time, the static assets and capitals, just as the dynamic time-assets and time-capitals aspect classifications one by one:  $T, A, C$ , or rather  $T-A$  and  $T-C$ . And if the property classification system is explicit N-fold ( $N \geq 3$ ) then let us denote this with  $S_{expl} \acute{e}s N_{expl}$ , while if it is implicit N-fold ( $N \geq 2$ ) then let us denote this with  $S_{impl} \acute{e}s N_{impl}$ .

Let us verify the theorem the explicit N-fold (I.) and the implicit N-fold (II.) onto cases separately.

(I.) This time, if we slightly reword this part of the theorem and use the introduced notations, we may write:

(1) For all complete  $S_{expl}$  is true that:  $N_{expl} \geq 3$  and is therein  $T$  and  $A$  and  $C$  property classification.

Let us suppose that the opposite of (1) is true, that is:

(2) For all complete  $S_{\text{expl}}$  is not true that:  $N_{\text{expl}} \geq 3$  and is therein  $T$  and  $A$  and  $C$  property classification. Or other: There is such complete  $S_{\text{expl}}$  on which is true that: or  $N_{\text{expl}} < 3$  and/or is not therein  $T$  and/or not  $A$  and/or not  $C$  property classification. (Here e.g. ' $T$  and/or  $A$ ' means that ' $T$  or  $A$ , or  $T$  and  $A$ '.)

This time in the complete  $S_{\text{expl}}$  let  $N_{\text{expl}} < 3$  and let its property classification system consist (possibly near other static property classifications) only from  $T$ , or  $A$ , or  $C$ , or  $A$  and  $C$ , or  $T$  and  $A$ , or  $T$  and  $C$ -aspect property classification, or it does not contain one of these nor. Or: let  $N_{\text{expl}} \geq 3$ , but let the complete  $S_{\text{expl}}$  consist (possibly near other static property classifications) only from  $T$ , or  $A$ , or  $C$ , or  $A$  and  $C$ , or  $T$  and  $A$ , or  $T$  and  $C$ -aspect property classification, or it does not contain one of these nor.

And by  $T_{21}/C_3$ : If the classification system of the gross property consists (possibly near other static property classifications) only from  $T$ , or  $A$ , or  $C$ , or  $A$  and  $C$ , or  $T$  and  $A$ , or  $T$  and  $C$ -aspect property classification, or it does not contain one of these nor, then such property classification system incomplete. This conversely confutes the statement which is under (2), consequently the statement by (1) is true.

(II.) If we again slightly reword this part of the theorem and use the introduced notations, we may write:

(1) For all complete  $S_{\text{impl}}$  is true that  $N_{\text{impl}} \geq 2$  and is therein  $T-A$  and  $T-C$  property classification. Let us suppose the opposite of this one:

(2) For all complete  $S_{\text{impl}}$  is not true that  $N_{\text{impl}} \geq 2$  and is therein  $T-A$  and  $T-C$  property classification. Or other: There is such complete  $S_{\text{impl}}$  on which is true that: or (A)  $N_{\text{impl}} < 2$  and/or (B) is not therein  $T-A$  and/or (C) not  $T-C$  property classification. We may write this statement (2) formally thus too:

(3)  $\exists S_{\text{impl}} P(S_{\text{impl}})$  where  $P(S_{\text{impl}}) = A \vee B \vee C$  and ' $\exists$ ' is an existential quantifier (it means: 'there is such'), and the symbol ' $\vee$ ' is the sign of the disjunction (aka: and/or); and  $P(S_{\text{impl}}) = A \vee B \vee C$  is on the  $S_{\text{impl}}$  relating statement ( $P$  = 'predicate'). [For example: logical value of  $A \vee B$ :  $A \vee B$  is true if, and only if, or only  $A$ , or only  $B$ , or  $A$  and  $B$  also is true. We may expand easily on the formula  $A \vee B \vee C$  the criterion of the truth, if we rewrite the formula  $A \vee B \vee C$  e.g. thus:  $A \vee B \vee C = (A \vee B) \vee C$ .]

Since  $A$  and  $B$  and  $C$  denote, one by one, true or false statements (we may denote this thus too: 1='true'; 0='false'), hence possibly the number of truth values of  $A \vee B \vee C$ :  $2^3 = 8$ . If we incorporate the following the table of truth values the meaning of  $A$  and  $B$  and  $C$  and their truth values, then we get the possibly truth values of  $A \vee B \vee C$ :

								Table of truth-values		
	A	∨	B	∨	C	A	B	C	A ∨ B ∨ C	
1.	$N_{imp} < 2$		T-A is not		T-C is	1	1	0	1	
2.	$N_{imp} < 2$		T-A is		T-C is not	1	0	1	1	
3.	$N_{imp} < 2$		T-A is not		T-C is not	1	1	1	1	
4.	$N_{imp} \geq 2$		T-A is		T-C is not	0	0	1	1	
5.	$N_{imp} \geq 2$		T-A is not		T-C is	0	1	0	1	
6.	$N_{imp} \geq 2$		T-A is not		T-C is not	0	1	1	1	
7.	$N_{imp} < 2$		T-A is		T-C is	1	0	0	1	
8.	$N_{imp} \geq 2$		T-A is		T-C is	0	0	0	0	

(1= true; 0 = false)

The 7<sup>th</sup> statement is formally true, but in fact it is self-contradiction. The 8<sup>th</sup> statement is formally a priori false, however verifies by content the part II./(1) of theorem. Hence we do not deal with these two statements.

Let us investigate so the first 6 statements.

We may diagnose on these that in the systems  $S_{imp1}$  or is not **T-A** or is not **T-C** property classification, or is neither. But this one contradicts to the proved theorem  $T_{21}/C_2$ . The statement II./(2) leads to contradiction hence its opposite the statement II./(1) is true.

We showed that the part I. and part II. of this theorem are true statements, consequently the theorem is true.

Q.e.d.

P.:

C.:  $T_{21}/C_2, T_{21}/C_3$

**Theorem 27:** In the  $(0;M]$  interval the difference (or if the decrease is negative, algebraic sum) of same type measure data of the economic events, which occurred for increase and /or decrease of the gross property, is equal with the main sum of static classification of the gross property which belongs to the **M**th time-point.

By axiom  $A_5$  in the property change class, in the  $(0;t]$  interval, apropos of the economic events came into existence difference (balance) of property increases and/or decreases equal to the static balance class in the **t**th time point belonging with sum, let it be either main or part sum.

Since by the condition  $t=M$  and the property change class is same to the gross property belonging with property change base class, hence, by  $A_5$ , in the  $(0;M]$  interval happened property changes' balance equal to with the main sum of static classification of the gross property in **M**th time-point.

Q.e.d.

P.: 1./ $T_{28}$ , 2./ $T_5$

C.: 1./ $A_5$ .

Theorem 28: With the formula  $A=C \geq 0$  represented incomplete property classification system (classic balance sheet) of gross property is transformable so that let it be complete.

By  $T_{21}/C_3$  with the formula

$$(1) A=C \geq 0$$

represented property classification system (classic balance sheet) of the gross property is incomplete, although is closed in point of the economist-specific economic events. If the formula (1) is transformable so that let it be satisfactorily informative, then by formula (1) represented the property classification system will be complete.

By definition: the property classification system is satisfactorily informative if it shows the economist's material position in a given time and at least the changes of its gross property to this time by the time-aspect property classification.

It is clear that with the formula  $E=F \geq 0$  represented property classification system shows the static material position in the  $t=M$  time-point. That let it be complete also it must show that the gross property is changing in  $(0;M]$  interval.

Therefore let us consider in  $t$ th time-point of  $(0;M]$  interval occurred all  $k$ th ( $k=1,2,\dots$ ) economic event's same type measure data (by  $A_{13}$ ), which is denoted with  $\mathbf{v}_k(t)$ . (The sign of the decrease is negative.) The measure data of the only structuring events must be counted twice with opposite sign, or not at all. Namely the  $t$ th main sum is invariant in point of these ( $T_{19}/C_1$ ). Let  $\mathbf{T}$  denote the algebraic sum of the property changes  $\mathbf{v}_k(t)$ . This time  $\mathbf{T}$  is equal with the main sums  $\mathbf{A} \geq 0$  and  $\mathbf{C} \geq 0$  of the gross property by  $T_{27}$  in the  $M$ th time-point, that is: (2)  $T=A=C \geq 0$ .

Since these data  $\mathbf{v}_k(t)$  are data of that economic events that occurred in  $(0;M]$  interval, where  $(0;M]$  divided on  $(t-1;t]$  parts ( $t=1,2,\dots,M$ ), hence these data  $\mathbf{v}_k(t)$  change (by  $A_5$ ) the part sums  $I(t)$  of time classes of the  $(0;M]$  interval. Thus  $I(t)$  is equal with algebraic sum of the values  $\mathbf{v}_k(t)$  [by  $A_5$ ], that values  $\mathbf{v}_k(t)$  belong to the  $t$ th time-point. And  $T$  is equal with sum of all  $I(t)$

by  $A_4$ . Hence  $\sum_{t=1}^M I(t) = T$  is true and (2)  $T=A=C \geq 0$  also, which already clearly is a complete explicit  $N$ -fold ( $N=3$ ) property classification system by  $T_{21}$ .

Now let  $A_i(t)$  denote ( $i=1,2,\dots,n$ ) the sum of changes of the  $i$ th asset-type in the  $(t-1;t]$  interval ( $t=1,2,\dots,M$ ). That is:  $A_i(t)$  is equal algebraic sum of the values  $\mathbf{v}_k(t)$  [by  $A_5$ ], which values belong to  $A_i(t)$ .

Additionally let  $C_j(t)$  denote ( $j=1,2,\dots,p$ ) the sum of changes of the  $j$ th capital-type in the  $(t-1;t]$  interval ( $t=1,2,\dots,M$ ). That is:  $C_j(t)$  is equal algebraic sum of the values  $\mathbf{v}_k(t)$  [by  $A_5$ ], which values belong to  $C_j(t)$ .

Now if we sum the all  $A_i(t)$  by  $i$  and  $t$ , just as the all  $C_j(t)$  by  $j$  and  $t$ , then we obtain (by  $A_4$ ,  $A_5$  and  $T_{27}$ ) the following formula:

$P_{GR}(M) = \sum_{t=1}^M \sum_{i=1}^n A_i(t) = \sum_{t=1}^M \sum_{j=1}^P C_j(t) \geq 0$ . This formula already clearly is a complete implicit N-fold (N=2) property classification system by  $T_{21}/C_2$ .

Q.e.d.

P.:

C.: 1./A<sub>4</sub>, A<sub>5</sub>, T<sub>19</sub>/C<sub>1</sub>, T<sub>21</sub>, T<sub>21</sub>/C<sub>2</sub>, T<sub>21</sub>/C<sub>3</sub>, T<sub>27</sub>.

Thus we not only proved this theorem, but we showed that process also with which with the  $A=C \geq 0$  formula represented property classification system will be complete. (This one can come in handy a shrewd for programmer, provided that perceives this information. ☺)

### The law of the material position

Theorem 29: The  $P_{GR}(M) = \sum_{t=1}^M \sum_{i=1}^n A_i(t) = \sum_{t=1}^M C_E(t) + D(t) \geq 0$  (where  $P_{GR}(M) = \sum_{t=1}^M \sum_{i=1}^n A_i(t) \leq D(t) \geq 0$  and

$C_E(t) \leq 0$ ; and  $t=1,2,\dots,M$ ;  $i=1,2,\dots,n$ ) formula represents the law of the material position. Mean of this law: The man and all other economist, from its birth to its death, its existence in all  $t$ th moment, (1) has gross property [ $P_{GR}(M) > 0$ ], but then has debt also [ $D(t) > 0$ ], (2)  $D(t)$  in the good case is significantly less, in bad case is greater than the gross property, (3) or it does have neither its property [ $P_{GR}(M) = 0$ ] its debt [ $D(t) = 0$ ] (this time it is pauper), (4) or its position worse at this one also because it has only debt [ $P_{GR}(t) = 0, D(t) > 0$ ] (this time it is pauper debtor). (5) And other case is not possible. (6) The material position of the economist and its all factors change in the time, the economist either economizes or leaves to itself its property, hence (7) its property, as its material position's either main factor, may investigate by N aspect (N $\geq$ 3), that is, at least by time, asset and capital-aspect (T<sub>29</sub>).

The following formula gives the model of the law of the material position:

$$P_{GR}(M) = \sum_{t=1}^M \sum_{i=1}^n A_i(t) = \sum_{t=1}^M C_E(t) + D(t) \geq 0 \quad \text{and} \quad P_{GR}(M) = \sum_{t=1}^M \sum_{i=1}^n A_i(t) \leq D(t) \geq 0,$$

just as  $V_S(t) \leq 0$  (where  $t=1,2,\dots,M$ ;  $i=1,2,\dots,n$ ).

Let us show the truth of statements (1),...,(7).

(1) If the economist has property in  $t$ th time-point (that is  $P_{GR}(M) \geq 0$  by T<sub>1</sub>), then it has debt also (by A<sub>7</sub>) and this time  $D(t) > 0$  by T<sub>2</sub>. The (1) statement so is true.

(2) If the economist has property and thus debt also by (1), then on the relationship of these is true:  $P_{GR}(t) \leq D(t) > 0$  by T<sub>1</sub>, T<sub>2</sub> and T<sub>3</sub>. The (2) statement so is true.

(3) But there is such case that some economist does have neither property nor debt in a  $t$ th time-point (yet or already), that is:  $P_{GR}(M) = 0$  and  $D(t) = 0$  by A<sub>2</sub>, A<sub>7</sub> (this time it is pauper). The (3) statement so is true.

(4) But such  $t$ th time-point may be also, when the economist does not have gross property (that is:  $P_{GR}(M) = 0$  by A<sub>2</sub>, A<sub>7</sub>), however it has debt (so  $D(t) > 0$  by A<sub>7</sub>, T<sub>2</sub> (this time it is pauper debtor). But

this time its equity is negative [that is: if  $P_{GR}(t)=C_E(t)+D(t)=0$  and  $D(t)>0$  by  $A_2$  és  $A_7$ , then  $D(t)=-C_E(t)>0$  by  $T_5$ .] The (4) statement so is true.

(5) And other case is not possible (by  $A_7$ ). The (5) statement so is true.

(6) The material position of the economist and its all factors change in the time, the economist either economizes (by  $T_{20}/C_1$ ) or leaves to itself its property (by  $T_{15}/C$ ) [the (6) statement so is true], hence

(7) its property, as its material position's either main factor, may investigate by  $N$  aspect ( $N \geq 3$ ), that is, at least by time, asset and capital-aspect (by  $T_{16}/C_3$ ). The (7) statement so is true.

For (1),..., (7) this theorem is true.

Q.e.d.

P.:

C.:  $A_2, A_7, T_1, T_2, T_3, T_5, T_{15}/C, T_{16}/C_3, T_{20}/C_1$ .

## 2. The base elements of theory of the property bookkeeping

### 2.1 Principles

#### 2.11 Definitions of the property bookkeeping

##### 2.111 The concepts of the general bookkeeping

1. I understand under the structure of an event the following ordered  $n$ -tuple or  $n$ -element ( $n \geq 4$ ) row-vector:

$$\begin{bmatrix} \text{time\_point\_of\_event} \\ \text{name\_ (description)\_of\_event} \\ \text{quantitative\_data\_of\_event} \\ \text{(monetary)\_value\_data\_of\_event} \\ \dots \\ \dots \\ x \end{bmatrix}^* = \begin{bmatrix} a_1 \\ a_2 \\ a_3 \\ a_4 \\ \dots \\ \dots \\ a_k \end{bmatrix}^* = \underline{a^{(e)*}}$$

2. The **documented event** is such event that its occurrence is proven<sup>67</sup> with the data-line of a document. The following formula shows the structure of it:

<sup>67</sup> I understand this juristic and economic in sense.

$$\begin{bmatrix} \text{time\_point\_of\_event} \\ \text{identification\_data\_of\_document} \\ \text{name\_description\_of\_event} \\ \text{quantitative\_data\_of\_event} \\ \text{(monetary)\_value\_data\_of\_event} \\ \dots \\ \dots \\ x \end{bmatrix}^* = \begin{bmatrix} a_1 \\ a_2 \\ a_3 \\ a_4 \\ a_5 \\ \dots \\ \dots \\ a_k \end{bmatrix}^* = \underline{a^{(de)^*}}$$

3. A **registration (data-base) is explicit chronologic** if its items (its records) ordered in sequence by its time-data else it is implicit chronologic.
4. A **query's result is** such **statement** which made a given registration (data-base) of data by any view-point.
5. The **bookkeeping is** the chronologic registration (data-base) of data-vectors (data-records) which defines a N-aspect ( $N \geq 2$ ) dynamic or dynamic and static balance sheet just as all result of query of this registration (data-base).
6. I will name to **bookkeeping event** in the bookkeeping recorded data-vector of any documented real or not real event which was complemented with the coordinates of the event. The following formula shows the structure of it:

$$\begin{bmatrix} \text{time\_point\_of\_event} \\ \text{identification\_data\_of\_document} \\ \text{name\_description\_of\_event} \\ \text{coordinates\_of\_event} \\ \text{quantitative\_data\_of\_event} \\ \text{(monetary)\_value\_data\_of\_event} \\ \dots \\ x \end{bmatrix}^* = \begin{bmatrix} a_1 \\ a_2 \\ a_3 \\ a_4 \\ a_5 \\ a_6 \\ \dots \\ a_k \end{bmatrix}^* = \underline{a^{(be)^*}}$$

7. **I will name** to **abstract event** that row vector with single element (1-tuple) which contains the data-type  $a_3$  this is called 'the name (description) of even', it is abstracted from all data-type of the documented or the bookkeeping event.
8. **I name** to standardized events those event-names that in the bookkeeping required using the concrete bookkeeping events on strictly name for  $a_3$  data-type. We constitute these events with standardization from the abstract events; and they all differ one from another formally (in view of the words or its the name's order or in view of the event's description) and by content (in view of the mean of the name or description of the event) too, *additionally the event coordinate n-tuple is clever, that is, real.*

9. **Faulty bookkeeping registration** that in which one or more or all data of one or more bookkeeping event is not same with the reality.
10. I name to **bookkeeping derivative** with the formula (F)  $\underline{y}_i'^* = [y_1, y_2, \dots, y_k]_{i'} = \underline{o}_i^* = \varphi'(x_i) = f'(e_i)^{68}$  given two the (F1)  $\underline{y}_i'^* = \varphi'(x_i)$  and the (F2)  $\underline{y}_i'^* = f'(e_i)$  **functions**, where  $i=1, 2, \dots, n$  is the number of standardized events;  $k$  is ( $1 \leq k \leq N-1$  and  $k, N$  are two integers) number of possible classification-aspects (without time-aspect; that we get by date of the event). In these formulas the  $\underline{y}_i'^* = [y_1, y_2, \dots, y_k]_{i'}$  vector shows by the mapping  $e_i \rightarrow \underline{y}_i'^* = [y_1, y_2, \dots, y_k]_{i'}$  gives to the standardized events  $e_i$  as to argument of function  $f'$  belonging the event-coordinates  $\underline{y}_i'^* = [y_1, y_2, \dots, y_k]_{i'}$ , as a  $k$ -element vector of the class-coherence. Additionally the set  $\mathbf{E}$  [ $e_i \in \mathbf{E}$  ( $i=1, 2, \dots, n$ )] is the domain of function  $f'$ , that is: the set of the possible standardized events or other: the set of possible inputs, while the set  $\mathbf{I}$  is the domain of function  $\varphi'$ , that is: the set of number  $i$  of the standardized events (the possible of mapping  $i=x_i \leftrightarrow e_i$  is given). Now  $\underline{y}_i'^* = [y_1, y_2, \dots, y_k]_{i'} = \underline{o}_i^*$  ( $i=1, 2, \dots, n$ ) is the value-set  $\mathbf{Y}' = \mathbf{O}$  ( $\underline{y}_i'^* \in \mathbf{Y}'$ ,  $\underline{o}_i^* \in \mathbf{O}$ ) of the two function (F1) and (F2), that is, the set of the possible class-coherences or other the outputs.
11. The **abstract automaton** (let it denote  $A$ ) is a **model** of the real automata. [Remarks: This model may be mathematical (algebraic) or geometrical (graph which consists in peaks and direct lines. We can be to define the abstract automaton with algebraic formula or with modified Cayley table or with the already mentioned graph.)]
12. We name to Mealy's abstract automaton with the
- $$(a1) \quad A^M = \langle \mathbf{S}, \mathbf{X}, \mathbf{Y}, \delta, \lambda \rangle$$
- formula's symbols denoted system, as such mathematical (algebraic) model, which consists the ordered 5-tuple  $\langle \mathbf{S}, \mathbf{X}, \mathbf{Y}, \delta, \lambda \rangle$ .
- From  $\langle \mathbf{S}, \mathbf{X}, \mathbf{Y}, \delta, \lambda \rangle$  the  $\mathbf{S}$ ,  $\mathbf{X}$  and  $\mathbf{Y}$  are such sets that have at least one element, that is: they are non-empty. The two symbols  $\delta$  and  $\lambda$  are read on the product-set  $\mathbf{S} \times \mathbf{X}$ , that is: on the set of the ordered pair  $\langle s, x \rangle$  (where  $s \in \mathbf{S}, x \in \mathbf{X}$ ), and these two symbols denote the  $\delta: \mathbf{S} \times \mathbf{X} \rightarrow \mathbf{S}$  and the  $\lambda: \mathbf{S} \times \mathbf{X} \rightarrow \mathbf{Y}$  functions, where:
- $\mathbf{S}$  is by the automaton  $A^M$  the **set of admissible states** and  $s \in \mathbf{S}$  is some status of  $A^M$ ;
  - $\mathbf{X}$  is by  $A^M$  **interpretable the set of input signs**, and  $x \in \mathbf{X}$  is an input sign;
  - $\mathbf{Y}$  is by  $A^M$  **publishable the set of output signs**, and  $y \in \mathbf{Y}$  a by  $A$  publishable output sign;

<sup>68</sup> The concept, function and the production of the bookkeeping derivative are readable with examples and thorough exposition in first part of my book on the 255<sup>th</sup>-267<sup>th</sup> pages.

The functions  $\delta$  and  $\lambda$  define the operation of the automaton  $A^M$  by the following:

- the **temporary function** is such two variables function which defines **the status changes** of the automaton  $A^M$  by input signs  $\mathbf{x}$ , that is: the formula of  $\delta$ :

$$(a2) \quad \delta(\mathbf{s}, \mathbf{x}) \in A$$

- the **output function** gives **the output signs** of  $A^M$  by input signs  $\mathbf{x}$  (if  $A^M$  can give out such output sign) and it is the two variable function of  $A^M$ , that is: the formula of  $\lambda$ :

$$(a3) \quad \lambda(\mathbf{s}, \mathbf{x}) \in Y.$$

This automaton  $A^M$  is **S-finite** if status set  $S$  of  $A^M$  is finite, and **finite** if the 3 sets of  $A^M$  are finite.

This automaton  $A^M$  is **total defined** if the functions  $\delta$  and  $\lambda$  are defined on all ordered pair  $\langle s, x \rangle$  ( $s \in S, x \in X$ ), else it is called **partial automaton**.

This automaton  $A^M$  is **determined** if the functions  $\delta$  and  $\lambda$  are single-valued, else it **is not determined**.

The automata, which are investigated by me, are all total defined and determined  $A^M$ .

We suppose yet the operation of these automata  $A^M$  that they operate into discrete time-scale, that is, they can get input sign and give out the output sign only in discrete time-points<sup>69</sup>. Accordingly, if the automaton  $A^M$  in some time-point is into the status  $\mathbf{s} \in S$  and this time it gets an input sign  $\mathbf{x} \in X$ , then it gets into the status  $\delta(\mathbf{s}, \mathbf{x}) \in S$  and it sends out an output sign  $\lambda(\mathbf{s}, \mathbf{x}) \in Y$  (assuming that it is not the automaton without output sign).

See the operation of the automaton  $A^M$  by the following schema (see below the figure a2):

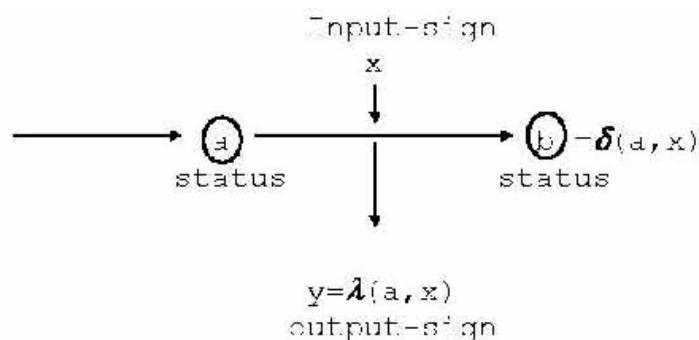

Figure a2

<sup>69</sup> *István Peák*: Introduction in the theory of the automata I. 8<sup>th</sup> page. (Textbook Publisher, Budapest, 1977.).

On the Figure a2 the horizontal arrow [a,b] shows the status change of the automaton  $A^M$  by the input sign  $x$  (upper vertical arrow). This time the automaton came from  $a$  into status  $b$ . The lower vertical arrow signs the output sign outgoing.

13. We name to the **without memory Mealy's automaton** (let it denote  $A^M_{A1}$ ) as the such special automaton whose the set  $S$  of its states consists from only element (this is denoted  $|S|=1$ ). The only status of such automaton  $A^M_{A1}$  is that it operates, that is: it receives input sign and prompt sends an output sign.

The temporary function of  $A^M_{A1}$ :

$$(a4) \quad \delta(s, x) = s,$$

that is: the status of the automaton  $A^M_{A1}$  does not change if it get an input sign  $x$ , because  $S$  of  $A^M_{A1}$  from  $x$  is independent.

Clear that in case  $A^M_{A1}$   $y$  depends only from  $x$  for (a4), hence the ' $s$ ' may leave from output function  $\lambda$ :

$$(a5) \quad \lambda(s, x) = \lambda(x) = y.$$

Hence the automaton  $A^M_{A1}$  may define following too:

$$(a6) \quad A^M_{A1} = \langle S, X, Y, \lambda \rangle$$

where  $x \in X$ ;  $y \in Y$  és  $|S|=1$ .

The (a6) algebraic model is reducible. We may leave everything from  $A^M_{A1}$  but the output function not. Namely, in point of fact the automaton  $A^M_{A1}$  corresponds to the known formula  $y=f(x)$ , where the set  $X$  is the domain of  $f(x)$  and the set  $Y$  is the value-set of  $y$ . The difference only that  $X$  and  $Y$  both finite and countable, that is: the value of  $x \in X$  and  $y \in Y$  may be only discrete.

Thus  $A^M_{A1}$  is equivalent with the following formula

$$(a7) \quad y_i = f(x_i)$$

wher  $i=1, 2, \dots, n$  and  $x_i \in X$ ;  $y_i \in Y$ .

Additionally: in our case the depended variable of the model  $A^M_{A1}$  must be written with such vector to which are at least two elements<sup>70</sup>. This model is modifies:

$$(a8) \quad \underline{y}_i = f(x_i),$$

where  $i=1, 2, \dots, n$  and  $\underline{y}_i$  is a  $n$ -tuple (in the traditional book-keeping this is 2-tuple, that is: ordered pair),  $x_i$  contains the name (or the describe) of the standardized event, in point of fact it is a text-variable.

Nevertheless the synthetical notation of the automaton  $A^M_{A1}$ :

$$(a8') \quad A^M_{A1} = \langle S, X, Y, \lambda = \underline{y}_i = f(x_i) \rangle$$

where  $x_i \in X$ ;  $\underline{y}_i \in Y$  and  $\underline{y}_i$  is a  $n$ -tuple ( $i=1, 2, \dots, n$ ) just as  $|S|=1$ .

<sup>70</sup> This vector has no geometrical meaning.

14. I name to **event-coordinate<sup>71</sup> designator automaton** the Mealy's<sup>72</sup> such abstract automaton which is without (status) memory and finite and discrete, additionally which is given with some function  $[\underline{y}_i'^* = \varphi'(x_i)$  or  $\underline{y}_i'^* = f'(e_i)$  ( $i=1,2,\dots,n$ )] of the bookkeeping derivative  $[\underline{y}_i'^* = [y_1, y_2, \dots, y_k]_{i'} = \underline{o}_i^* = \varphi'(x_i) = f'(e_i)]$ ; and which is the model of such real event-coordinate designator automaton which defines the event-coordinates of standardized economic event  $e_i$  (for all  $i$ ).

### 2.112 The concepts of the property bookkeeping<sup>73</sup>

1. The **not real economic event** is such change of the material position which is apparent and shown merely in bookkeeping-technical causes.
2. **Property bookkeeping is** that special bookkeeping which defines an N-aspect ( $N \geq 2$ ) dynamic or dynamic and static property balance sheet.
3. Under the **aberration of the reality** I understand the discrepancy of by inventory material position or rather the inventory before occurred economic events according to material position, that is, the discrepancy of the main factors of the original material position, from any cause.
4. I name to **abstract bookkeeping automaton** that the complex abstract automaton which is composite from more, without memory, finite and discrete Mealy's abstract automaton, and which is the model of that real bookkeeping automaton which gives the data of the  $j$ th bookkeeping event ( $j=1,2,\dots,n$ ). The formula of this one is the following:

$$[\underline{y}_j'^*, \underline{z}_j^*, \underline{c}_j^*, e_i]_j = [f_j'(e_i), g_j(e_i), \underline{c}_j^*, e_i]_j$$

where:

<sup>71</sup> The data of the event-coordinates in the traditional double bookkeeping is known as the data-pair of an account coherence which shows the alphabetical and/or numerical signs of the debit account and the credit account in the 'T' system.

<sup>72</sup> You may read more information on the Mealy's abstract automatons yet in the first part of my book, in its 3.2 point of the chapter IV also.

<sup>73</sup> The concepts of the **general bookkeeping** and the **special bookkeepings** differentiate from each other on this point. We may class the special bookkeepings on divers methods. The either aspect of the classification may be that the bookkeeping happens **by document** or does not. The other aspect of the classification may be that the quantity or monetary value, etc. of elements of the base set may be or may be not **negative** that is: between the changes as elements may be or may be not **decrement**. The modern N-entry property bookkeeping, on that we discuss in this book, can rate on the class of the documented bookkeepings where in this class is decrement too (see for example the **appendix 1**). But for example the following special bookkeepings also rate in this class: **the registration of the phone numbers** (its document is the contract of the service), **the bookkeeping of the library lending** (its document is the ticket of the lending). The following special bookkeepings, in what there is not base document and decrement, rate on the other class. These are for example: **the bookkeeping of knowledge-level in the school** (data base of this one is the grade book and its balance sheet is a knowledge-level balance sheet; see for example the **appendix 2**); and so **the bookkeeping of costs of the telephone-callings**. This one results a 4-aspect that is: time-caller-called-cellular or wired phone-aspect balance sheet (see e.g. the **appendix 3**). But we can rate also into this class e.g. the bookkeeping of changes of a galaxy in the astronomy and the bookkeeping of the distribution of the red and yellow pages in the football©.

- $\underline{y}_j'^* = [y_1, y_2, \dots, y_k]_j' = f_j'(e_i)$  is the **abstract bookkeeping automaton**; it gives the value of the bookkeeping derivative on place  $e_i$  (that is: at the  $e_i$  standardized economic events);
- $\underline{z}_j^* = [z_1, z_2, \dots, z_o]_j = g_j(e_i)$  is such abstract automaton which yields other the vector of the from  $e_i$  dependent meta data. [From this automaton may be more too. For example:  $g_{j1}^{\text{VAT}}(e_i)$  may be the **abstract VAT-automata** (VAT='Value-added tax'); and  $g_{j2}^q(e_i)$  may be the abstract automaton of the measure units, etc.];
- $\underline{c}_j^* = [c_1, c_2, \dots, c_r]_j$  is the vector of the data of the explicit given concrete documented economic events (as e.g. time-point, document-identifier, money, quantity, etc.).

The mean and value of the indexes:

- $i=1, 2, \dots, n$ , is the number of the standardized economic events, while  $j=1, 2, \dots, m$  is the number of the documented economic events or rather bookkeeping events in the period;
  - $k=1, 2, \dots, \ell$  is the number of elements of the class coherence vector  $\underline{y}_j'^*$  without the time;
  - $o=1, 2, \dots, q$  is the number of elements of the vector  $\underline{z}_j^*$ ;
  - $r=1, 2, \dots, u$  is number of elements of the vector  $\underline{c}_j^*$ .
5. I name to **the abstract automaton of the traffics and balances data query** (briefly: to **the traffics and balances query automaton** or only simply **query automaton**) that the modified initial Mealy automaton (denoted by  $\Lambda^Q$ ) which has two independent input and one output. This  $\Lambda^Q$  is the model of from the bookkeeping data base query real automaton which queries the traffics and balances data of asset or capital-aspect property type. See the schema of this automaton  $\Lambda^Q$  on the figure a3 below:

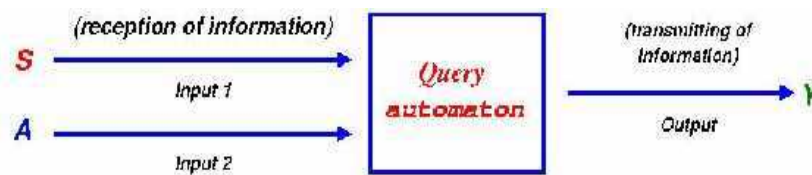

Figure a3

This query automaton  $\Lambda^Q$  is symbolized with the next algebraic model (as ordered 7-tuple)

$$\Lambda^Q = \langle S, \underline{s}_0, P, R, Y, \delta, \lambda \rangle$$

where:

- $S$  is status-set of the  $\Lambda^Q$  which consists from the status-vectors  $\underline{s}_j \in S$  ( $j=0, 1, 2, \dots, m$ );
- $\underline{s}_0 \in S$  is a status-vector, it is the vector of beginner status of  $\Lambda^Q$ ;

- $\mathbf{P}=\{\mathbf{p}\}$  is the number 1 input-sign set of  $\Lambda^Q$ , in which is the p-sign property-type (aka: e.g. a bookkeeping account's number  $\mathbf{p}$  in the traditional bookkeeping); this input sign  $\mathbf{p}$  only element of the set  $\mathbf{P}$ ;
- $\mathbf{R}$  is the number 2 input-sign set of  $\Lambda^Q$ , which consists from the input vectors  $\underline{\mathbf{r}}_j^*=\underline{\mathbf{r}}_j^*(\underline{\mathbf{c}}_j^*,e_i)\in\mathbf{R}$  ( $j=1,2,\dots,m$ ;  $i=1,2,\dots,n$ ) as input words; and other:  $\underline{\mathbf{r}}_j^*$  is not other as the  $j$ th row-vector of bookkeeping data base matrix  $\underline{\mathbf{R}}$  which writes down the  $j$ th bookkeeping event by  $\underline{\mathbf{c}}_j^*$  and  $e_i$  (cf. definition 4.);
- $\mathbf{Y}$  is output-sign set of  $\Lambda^Q$ , it has  $m$  elements ( $j=1,2,\dots,m$ ) and  $\underline{\mathbf{y}}_j^*\in\mathbf{Y}$  consists from output row-vectors;
- $\delta(\underline{\mathbf{s}}_j,\underline{\mathbf{r}}_j^*)=\underline{\mathbf{s}}_{j+1}\in\mathbf{S}$  is  $\Lambda^Q$ 's two variables temporary function, which gives that if  $\Lambda^Q$  in status  $\underline{\mathbf{s}}_j$  gets a input word  $\underline{\mathbf{r}}_j^*$  then what will be its next status;
- $\lambda(\underline{\mathbf{s}}_j,\underline{\mathbf{r}}_j^*,\mathbf{p})=\underline{\mathbf{y}}_j^*\in\mathbf{Y}$  is  $\Lambda^Q$ 's three variables output function, which gives that if  $\Lambda^Q$  in status  $\underline{\mathbf{s}}_j$  gets an input word  $\underline{\mathbf{r}}_j^*$  and an input-sign  $\mathbf{p}$  then  $\Lambda^Q$  what output-sign gives out.

The query automaton  $\Lambda^Q$  has additional features:

The  $\underline{\mathbf{s}}_0\in\mathbf{S}$  is the automaton's beginner status-vector; its value always the null-vector ( $\underline{\mathbf{s}}_0=\underline{\mathbf{0}}$ ), in which  $\Lambda^Q$  prompt returns if  $\Lambda^Q$  passed on its  $m$ th status. The temporary function  $\delta$  of  $\Lambda^Q$  yields this.

The status-vector  $\underline{\mathbf{s}}_j=[\mathbf{s}_{j1},\mathbf{s}_{j2},\mathbf{s}_{j3}]^*\in\mathbf{S}$  is a 3-tuple of numbers. Its elements: the value of  $\mathbf{s}_{j1}$  is to the  $j$  cumulated amount of the debit data ( $\mathbf{s}_{j1}=\mathbf{S}_D$ ); the value of  $\mathbf{s}_{j2}$  is to the  $j$  cumulated amount of the credit data ( $\mathbf{s}_{j2}=\mathbf{S}_C$ ); the value of  $\mathbf{s}_{j3}$  is to the  $j$  counted balance of D and C ( $\mathbf{s}_{j3}=\mathbf{B}=\mathbf{S}_D+\mathbf{S}_C\leq 0$ , ahol  $\mathbf{S}_D\geq 0$  és  $\mathbf{S}_C\leq 0$ ).

The already said bookkeeping data base  $\mathbf{R}$  is the set of the bookkeeping data-records  $\underline{\mathbf{r}}_j^*=\underline{\mathbf{r}}_j^*(\underline{\mathbf{c}}_j^*,e_i)\in\mathbf{R}$ , and the number  $\mathbf{v}$  of elements  $\underline{\mathbf{r}}_j^*$ :  $\mathbf{v}=(\ell+\mathbf{q}+\mathbf{u})+1$  (for all  $j$ ).

The row-vector  $\underline{\mathbf{y}}_j^*$ , as output word, is not other as the economic events of bookkeeping data base  $\mathbf{R}$  with query (with filtration) obtained the row-vector  $\underline{\mathbf{y}}_j^*$  of the  $j$ th output data. Let this be with 9 elements. These are:  $\underline{\mathbf{Y}}_j^*=[\mathbf{Y}_{j1},\mathbf{Y}_{j2},\mathbf{Y}_{j3},\mathbf{Y}_{j4},\mathbf{Y}_{j5},\mathbf{Y}_{j6},\mathbf{Y}_{j7},\mathbf{Y}_{j8},\mathbf{Y}_{j9}]^*$ , and  $\underline{\mathbf{y}}_j^*$  contains in order the data of the property-type  $\mathbf{p}$  (in traditional bookkeeping this is the  $\mathbf{p}$  account) by next: 1.) the identifier data  $\mathbf{p}$  of the property-type (in traditional bookkeeping this is the identifier data  $\mathbf{p}$  of the account); 2.) the time-point ( $\mathbf{t}$ ) of the economic events, 3.) the document's identifier data ( $\mathbf{d}$ ) 4.) the event's name ( $\mathbf{N}$ ), 5.) the sum of debit side ( $\mathbf{D}\geq 0$ ), 6.) the total debit traffic ( $\mathbf{S}_D$ ) 7.) the sum of credit side ( $\mathbf{C}\leq 0$ ), 8.) the total credit traffic ( $\mathbf{S}_C$ ) 9.) the sum of the balance:  $\mathbf{B}=\mathbf{S}_D+\mathbf{S}_C\leq 0$ . (Remark: in  $\underline{\mathbf{y}}_j^*$  or only  $\mathbf{D}>0$  or only  $\mathbf{C}<0$ , that is both clearly are not possible non-zero because so real economic event does not exist.)

The temporary function of the query automaton  $\Lambda^Q$  with two variables has the following formulas:

$$(a17) \quad \delta(\underline{s}_0, \mathbf{x}) = \delta(\underline{s}_0, \mathbf{p}) = \underline{a}_1, \text{ ha } \mathbf{x} = \mathbf{p}, \text{ ha } \underline{s}_j = \underline{s}_0;$$

$$(a17') \quad \delta(\underline{s}_j, \mathbf{x}) = \delta(\underline{s}_j, \underline{\mathbf{r}}_j^*) = \begin{cases} \underline{s}_{j+1} & \text{ha } 1 \leq j < m \\ \underline{s}_0 & \text{ha } j = m \end{cases} \quad (j=1, 2, \dots, m).$$

where  $\mathbf{x} = \underline{\mathbf{r}}_j^*$  if  $j=1, 2, \dots, m$ .

The output function of the query automaton  $\Lambda^Q$  with three variables has the following formula:

$$(a18) \quad \lambda(\underline{s}_j, \underline{\mathbf{r}}_j^*, \mathbf{p}) = \underline{\mathbf{y}}_j^* \text{ if } j=1, 2, \dots, m.$$

The automaton  $\Lambda^Q$  as a matter of fact is a so-called sequential machine (see the figure a4 where we may see such graph which shows the operate of  $\Lambda^Q$ ). If  $\Lambda^Q$  get the input sign  $\mathbf{p}$  then it prompt moves from beginner status  $\underline{s}_0 \in \mathbf{S}$  and takes up the status  $\underline{s}_1$ ; then after this, the affect of these input signs  $\underline{\mathbf{r}}_1^*, \underline{\mathbf{r}}_2^*, \dots, \underline{\mathbf{r}}_j^*, \dots, \underline{\mathbf{r}}_{m-1}^*$  ( $\underline{\mathbf{r}}_j^* \in \mathbf{R}$ ) the  $\Lambda^Q$  gets into its middle states

$$\underline{s}_2, \dots, \underline{s}_j, \dots, \underline{s}_{m-1} \in \mathbf{S},$$

and it sends out the row-vector  $\underline{\mathbf{y}}_j^* \in \mathbf{Y}$  of the output signs ( $j=1, 2, \dots, m-1$ ). Finally, after the status  $\underline{s}_m$  the affect of input sign  $\underline{\mathbf{r}}_m^*$  it sends out the last output sign  $\underline{\mathbf{y}}_m^* \in \mathbf{Y}$  then it returns into the beginner status  $\underline{s}_0 \in \mathbf{S}$ .

We may define the concrete form of the output function by the following:

Let us suppose that the bookkeeping data-record  $\underline{\mathbf{r}}_j^*$  has 6 elements. These are:  $\underline{\mathbf{r}}_j^* = [\mathbf{r}_{j1} = \mathbf{t}, \mathbf{r}_{j2} = \mathbf{d}, \mathbf{r}_{j3} = \mathbf{N}, \mathbf{r}_{j4}, \mathbf{r}_{j5}, \mathbf{r}_{j6}]$ , where is 1. the time-point ( $\mathbf{t}$ ) of the event, 2. the document number ( $\mathbf{d}$ ) of the event, 3. the name ( $\mathbf{N}$ ) of the event, 4. the identifier ( $\mathbf{r}_{j4}$ ) of the debit property-type (debit account in the traditional bookkeeping), 5. the identifier ( $\mathbf{r}_{j5}$ ) of the credit property-type (credit account in the traditional bookkeeping), 6. money sum ( $\mathbf{r}_{j6}$ ) of the property change.

Additionally let  $\mathbf{I}_{dp}$  be an indicator function, its value 1 if  $\mathbf{p}$  same the value of the debit identifier  $\mathbf{r}_{j4}$  else 0; and let  $\mathbf{I}_{cp}$  be an other indicator function, its value -1 if  $\mathbf{p}$  same the value of the credit identifier  $\mathbf{r}_{j5}$  else 0.

Let  $\mathbf{D}$  denote the debit sum of the property-type  $\mathbf{p}$  and let  $\mathbf{D} = \mathbf{I}_{dp} \cdot \mathbf{r}_{j6} \geq 0$ , and let  $\mathbf{C}$  denote the credit sum of the property-type  $\mathbf{p}$  and let  $\mathbf{C} = \mathbf{I}_{cp} \cdot \mathbf{r}_{j6} \leq 0$ , ( $j=1, 2, \dots, m$ ).

Let  $\mathbf{S}_D$  denote the sum of the debit traffic and let

$$(a19) \quad \mathbf{S}_D = \mathbf{s}_{j1} = \mathbf{s}_{j-1,1} + \mathbf{D} \geq 0 \quad (j=1, 2, \dots, m).$$

Let  $\mathbf{S}_C$  denote the sum of the credit traffic and let

$$(a20) \quad \underline{S}_C = \underline{s}_{j2} = \underline{s}_{j-1,2} + \underline{C} \leq 0 \quad (j=1,2,\dots,m).$$

Yet let  $\underline{B}$  denote the value of the status variable  $\underline{s}_{j3}$  as balance-memory ( $j=1,2,\dots,m$ ), and thus

$$(a21) \quad \underline{B} = \underline{s}_{j3} = \underline{s}_{j-1,3} + (\underline{D} + \underline{C}) \leq 0 \quad (j=1,2,\dots,m).$$

The values of elements of the output-vector  $\underline{y}_j^*$

$$(a22) \quad \underline{y}_j^* = [\underline{p}, \underline{t}, \underline{d}, \underline{N}, \underline{D}, \underline{S}_D, \underline{C}, \underline{S}_C, \underline{B}] \quad (j=1,2,\dots,m).$$

The figure a4 shows this initial and modified Mealy automaton  $\Lambda^0$  the operating schema with directed graph below (Figure a4):

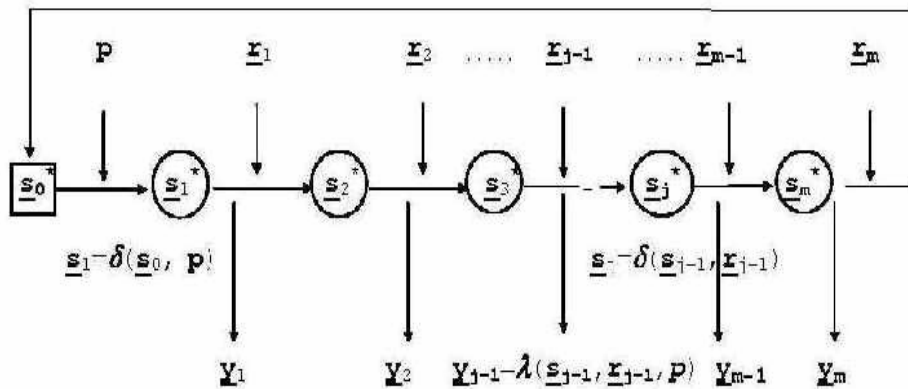

Figure a4

6. I name to **cumulative statement maker** (or traditionally: **trial balance query**) **abstract automaton** that modified initial Mealy's automaton (denoted with  $\Lambda^{TB}$ ) which is in the midst of maker process without output sign, and it is so-called Rabin-Scott abstract automaton. This model of such real automaton which gives out only output sign whenever its status is  $F = \{s_m\}$ ; and its output sign (in the traditional bookkeeping it is called to the trial balance) consists from data of the identifiers  $s_1, s_2, \dots, s_p$  by A or C-aspect property-types' balances (these are the ledger's accounts in the traditional bookkeeping). Its formula

$$\Lambda^{TB} = \langle \underline{S}, \underline{s}_0, \underline{P}, \underline{R}, \underline{Y}, \alpha_p, \delta, \lambda, F \rangle$$

Is ordered 9-tuple, where

-  $\underline{S}$  is status-set of the  $\Lambda^{TB}$  which consists from the status-vectors  $\underline{s}_j \in \underline{S}$  ( $j=0,1,2,\dots,m$ );

-  $\underline{s}_0 \in \underline{S}$  is a beginner status-vector, which is the vector of beginner status of  $\Lambda^{TB}$ ;

-  $\underline{P} = \{p_1, p_2, \dots, p_k, \dots, p_q\}$  is the set of  $q$  pieces class identifiers of the A or C-aspect all class (they are accounts in traditional bookkeeping) of the property ( $\underline{P}$  is the input-sign set 1.);

-  $\underline{R}$  is the bookkeeping database ( $\underline{R}$  is the input-sign set 2.);

-  $\underline{Y} = \{\lambda(\underline{s}_m, \underline{r}_m^*) = \underline{y}^*\}$  is the set of  $\Lambda^{TB}$  which consists an element the only output-vector, where  $\underline{s}_m$  is the final status of  $\Lambda^{TB}$ ;

- $\alpha_p(\underline{s}_0, p_k) = p_{k+1}$  ( $k=0, 1, 2, \dots, q-1$ ) is that input function which defines the new value of the next input sign  $p_k$  if  $\Lambda^{FK}$  gets into  $\underline{s}_0$ ;
- $\delta$  is the temporary function (cf. definition 5);
- $\lambda$  is the output function (cf. definition 5);
- $F = \{\underline{s}_m\}$  is the set of final status of the  $\Lambda^{TB}$ , it consists only element  $\underline{s}_m$ .

The figure a5 below shows the operating of  $\Lambda^{FK}$ :

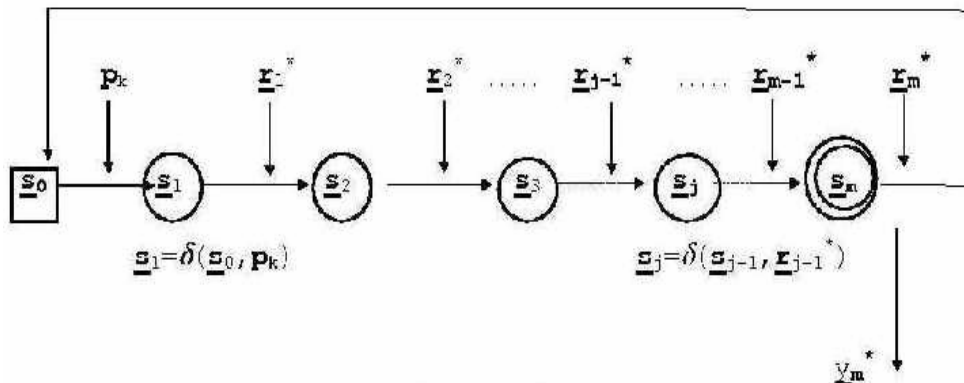

Figure a5

## 2.12 The axioms of the property bookkeeping

### 2.121 The documentary principle

1. The bookkeeping of all economic events happens from data of document of the events ( $A_1$ ).

P.: 2./ $T_1$ .

### 2.122 The general bookkeeping principles of undefinable imperishableness of the truth-untruth dilemma

2. The probability ( $p'$ ) of faulty imperishableness of the uncontrolled bookkeeping is always greater than zero and less than one at a given time ( $0 < p' < 1$ ) ( $A_2$ ).

P.: 2./ $T_3$ .

3. **The any data of some bookkeeping event equals or does not equal to the bookkeeping event corresponding event with same type data**, that is: the data of bookkeeping event is real or not; the corresponding data of documented event is whether faultless or no, and its bookkeeping is whether faultless or no. **This problem is undefinable without specialistic controlling**, namely: if we do not collate the data of the bookkeeping event with the real data of event ( $A_3$ ).

P.: 2./ $T_4$ .

4. **The any data of the inventory equals or does not equal to the inventory corresponding real event with same type data**, that is:

the data of the inventory is real or not; the data of inventory is whether faultless or no. **This problem is undefinable without specialistic controlling**, i.e. if we do not collate the data of the inventory with the real data of real event ( $A_4$ ).

P.: 2./ $T_4$ .

### 2.123 The principle of the inadequate controller automatons

5. The property bookkeeping faultless imperishableness not provable and not confutable from the formulas  $A=C$  ( $A=L+E$ ) and/or  $\sum Dr = \sum Cr$  ( $A_5$ ).

P.: 2./ $T_4$ .

### 2.124 The principle of economist-dependent of the abstract events

6. We can squarely assign a such finite set to any economist which consists from pair-wise different abstract economic events and this events are able on it that we define with them the possible changes of material position of the economist ( $A_6$ ).

P.: 2./ $T_5$ .

## 2.2 The theorems and their proofs

### Equivalence and isomorphism

Theorem 1: The data-vectors of the economic event and the to it corresponding bookkeeping event are equivalent in point of their data which characterizes the change of material position of the economist (2./ $T_1$ ).

Let  $\underline{e}_i$  denote the data-vector of the  $i$ th economic event ( $i=1,2,\dots,n$ ). But we may book only from document's data (by 2./ $A_1$ ), hence let  $\underline{d}_i$  denote the data-vector of the  $i$ th documented economic event and let  $\underline{b}_i$  denote the data-vector of the  $i$ th bookkeeping event (see the definitions). The vector  $\underline{d}_i$  differs from vector  $\underline{e}_i$  in point of data's intension only in its document identifier data  $a_2(\underline{d}_i)$  by relating definitions and the following figure e1. But there is not need on the document identifier data in point of characterization of change of the material position. Hence we can abstract from this data, as if it would not also be. Consequently it is true in point of characterization of change of the material position that  $\underline{e}_i \equiv \underline{d}_i$  (the symbol ' $\equiv$ ' means e.g. that ' $\underline{e}_i$  and  $\underline{d}_i$  is equivalent').

However  $\underline{b}_i$  differs from  $\underline{e}_i$  and  $\underline{d}_i$  only in the data  $a_4(\underline{b}_i)$  of the event coordinates. This data  $a_4(\underline{b}_i)$  is not other as the data  $a_3$  of  $\underline{d}_i$  and  $\underline{b}_i$  or rather the data  $a_2$  of  $\underline{e}_i$  which is the formalized version of the verbal data 'name (or describe) of event', that is, it is the data of the event coordinates by definition. We may say that both the verbal  $a_2(\underline{e}_i)$ ,  $a_3(\underline{d}_i)$  and  $a_3(\underline{b}_i)$  just as the formal-

ized  $a_4(\underline{b}_i)$  denote the final property classes and their change's character (such as increase or decrease or the structure's change). Consequently this data are equivalent in point of their contents (1./A<sub>14</sub>). [Actually the data  $a_3(\underline{b}_i)$  is in  $\underline{b}_i$  only for control and verbal notation (name).] However we can abstract from data  $a_2(\underline{b}_i)$  the already said for cause, as if it would not also be. Thus we get with the comparison of content of the data-structures the followings:

<u>The data's content</u>	<u>e<sub>i</sub></u>	<u>d<sub>i</sub></u>	<u>d<sub>i</sub></u>	<u>b<sub>i</sub></u>
[time-point]	$a_1(\underline{e}_i) \equiv a_1(\underline{d}_i)$	and	$a_1(\underline{d}_i) \equiv a_1(\underline{b}_i)$ ,	
[event-name]	$a_2(\underline{e}_i) \equiv a_3(\underline{d}_i)$	and	$a_3(\underline{d}_i) \equiv a_3(\underline{b}_i) \equiv a_4(\underline{b}_i)$ ,	
[quantity]	$a_3(\underline{e}_i) \equiv a_5(\underline{d}_i)$	and	$a_4(\underline{d}_i) \equiv a_5(\underline{b}_i)$ ,	
[money-value]	$a_4(\underline{e}_i) \equiv a_6(\underline{d}_i)$	and	$a_5(\underline{d}_i) \equiv a_6(\underline{b}_i)$ ,	

Figure e1

That is: from the data-content which influences the material position the followings hold:  $\underline{e}_i \equiv \underline{d}_i$  and  $\underline{d}_i \equiv \underline{b}_i$ . But then is true that:  $\underline{e}_i \equiv \underline{b}_i$  because the equivalence is transitive.

Q.e.d.

P.: 2./T<sub>6</sub>.

C.: 1./A<sub>14</sub>, 2./A<sub>1</sub>.

**Theorem 2:** In the bookkeeping of the property the indirect image of the economic events just as apropos of the economic events nascent property and debt or rather its system of the classification makes an appearance in the form of bookkeeping events or rather by bookkeeping events (2./T<sub>2</sub>).

Let  $\mathbf{E}$  be a finite and non-empty set, wherein the economic events  $e_i \in \mathbf{E}$  ( $i=1,2,\dots,m$ ), in a given interval, change the main sum of property and the debt just as upbuild their property classification system by 1./T<sub>20</sub>/C<sub>7</sub>. Additionally let  $d_i$  denote a documented economic event and let  $\mathbf{D}$  be a finite and non-empty set of the documented economic events, that is:  $d_i \in \mathbf{D}$ . And let  $\mathbf{B}$  denote an also finite and non-empty set of the bookkeeping events which perform in the bookkeeping registration  $\mathbf{B}$ , that is:  $b_i \in \mathbf{B}$ .

Now let us assign by a given rule the economic events to the bookkeeping events, but the data of the economic events also contains document (by 2./A<sub>2</sub>) or rather documented economic event interposing. This operate, also known as mapping, so will be indirect. (It also is called to composite mapping.)

1) The **first object-element** is the economic events  $e_i$ .

Let  $\phi$  be a mapping from  $\mathbf{E}$  onto  $\mathbf{D}$ . The  $\phi$  means that the mapping's rule is following: the data of the documented economic event  $d_i \in \mathbf{D}$  is same the economic event  $e_i \in \mathbf{E}$  with by content corresponding data ( $i=1,2,\dots,m$ ), aside from the identifier of the document.

2) The **first image-element** is  $d_i$  that is the documented economic event. This mapping  $\phi$  is mutually unequivocal, because to any economic event  $e_i$  belongs one and only one documented economic event  $d_i$  and vice versa (by 2./T<sub>1</sub>). We can express this mapping  $\phi$  with the following symbols too:  $e_i \leftrightarrow \phi(e_i) = d_i$  and the symbol ' $\leftrightarrow$ ' means that the mapping  $\phi$  is mutually unequivocal. This image-element  $d_i$  is at the same time the **second object-element** together with its data.

Let  $\psi$  be a mapping from  $D$  onto  $B$ . The  $\psi$  means that the mapping's rule is following: the data of the documented economic event  $d_i \in D$  is same the bookkeeping event  $b_i \in B$  with by content corresponding data ( $i=1,2,\dots,m$ ) (by 2./T<sub>1</sub>).

3) The second **image-element** is  $b_i$  that is the bookkeeping event. We can express this mapping  $\psi$  with the following symbols too:  $d_i \leftrightarrow \psi(d_i) = b_i$ ; thus  $\psi$  is mutually unequivocal.

The composite mapping is the following:

$$e_i \leftrightarrow \psi[\phi(e_i)] = b_i \quad (i=1,2,\dots,m).$$

Additionally: the algebraic sum of quantity or monetary value data of the economic events  $e_i \in E$  ( $i=1,2,\dots,m$ ), in a given interval, change and upbuild the main sum of property and the debt just as their property classification system by 1./T<sub>20</sub>/C<sub>7</sub>.

But  $e_i \equiv b_i$  by 2./T<sub>1</sub>, thus the theorem is true.

Q.e.d.

P.: 2./T<sub>2</sub>/C<sub>1</sub>, C<sub>2</sub>.

C.: 1./T<sub>20</sub>/C<sub>7</sub>, 2./A<sub>1</sub>, T<sub>1</sub>.

Corollary 1: The image of the bookkeeping registration as image of factors and changes of the material position and this mapping's object in point of its character is necessarily equivalent (2./T<sub>2</sub>/C<sub>1</sub>).

Q.e.d.

P.:

C.: 2./T<sub>2</sub>.

Corollary 2: The theorems and laws of the property theory hold in same form and with same content in the bookkeeping too (vice versa in generally this is not true) because in the property theory given system and the bookkeeping's system are isomorphic (2./T<sub>2</sub>/C<sub>2</sub>).

Q.e.d.

P.:

C.: 2./T<sub>2</sub>

### **The uncontrolled bookkeeping and inventory through involved truth-untruth dilemma and the law of "square control"**

Theorem 3: We can not consider to 100 percent unto corresponding the data of the uncontrolled property bookkeeping registration with the real data of the occurred economic events in a given time-point  $t$ .

The theorem otherwise:

The probability ( $p$ ) of unfaulty imperishableness of the uncontrolled property bookkeeping is always greater than zero and less than one at a given time-point  $t$  ( $0 < p < 1$ ).

Let  $E_F$  denote the event that the uncontrolled property bookkeeping is faulty,  $E_{UF}$  that it is unfaulty. Let  $H$  denote that  $E_F$  and  $E_{UF}$  occurred together, this time we write:  $E_F \cup E_{UF} = H$ .  $H$  means that in point of the faulty or unfaulty imperishableness of the uncontrolled property bookkeeping subsequential total set of the events or other: total event-system of it.  $E_F$  and  $E_{UF}$  close off each other pair-wise [ $E_F \cap E_{UF} = \emptyset$ ]; that is: together both can not occur. However then some but alone either of them occurs certainly. Additionally let  $\bar{H}$  denote the complement of  $H$  on which the following formula holds:

$$\bar{H} = \overline{E_F \cup E_{UF}} = \emptyset.$$

The expressive denotation of  $\bar{H}$  is that:  $E_F$  and  $E_{UF}$  both together can not occur because it is clearly the impossible event ( $'E_F \cap E_{UF} = \emptyset'$  denotes this).

The probability of set  $H$  (that is: the probability of the certain event) is 1 by the axiom II of the probability theory. We can denote this with  $P(H) = 1$ . Because that event occurs certainly that: the uncontrolled property bookkeeping registration will be faulty or unfaulty in a given time-point  $t$ . Let  $P(E_F) = p'$  denotes the measure of probability of faulty imperishableness of the uncontrolled property bookkeeping and  $P(E_{UF}) = p$  denotes the measure of probability of unfaulty imperishableness of it.

This time I have:  $0 < p < 1$ .

Now by 2./A<sub>2</sub>: "The probability ( $p'$ ) of faulty imperishableness of the uncontrolled property bookkeeping is always greater than zero and less than one at a given time ( $0 < p' < 1$ )."

But the uncontrolled property bookkeeping registration has two possible outputs which are close off each other [ $E_F \cap E_{UF} = \emptyset$ ] and they create a total event-system [ $E_F \cup E_{UF} = H$ ]. Hence the following formula holds by the axioms<sup>74</sup> I, II and III of the probability theory:

$$(a) \quad 0 < P(E_F \cup E_{UF}) = P(E_F) + P(E_{UF}) = P(H) = 1.$$

The following inequality (b) arises from equality  $P(E_F) = p'$  and  $P(E_{UF}) = p$  with substitution  $p'$  and  $p$  into (a):

$$(b) \quad 0 < p' + p = 1.$$

But we get from equality  $p' + p = 1$

$$(c) \quad p' = 1 - p.$$

However  $1 > p' > 0$  holds by 2./A<sub>2</sub>. This time we may use again that  $p' = 1 - p$ . We may write for  $p'$

$$(d) \quad 1 > 1 - p > 0.$$

---

<sup>74</sup> These perform here as the explicit named rules of the probability theory.

But we can get with rearrangement from formula (d):  $0 < p < 1$ . So this formula (d), as the statement of this theorem, is true, where 1 equal with the 100 percent of the immaculacy.

Q.e.d.

P.:

C.:  $2./A_2$ .

Theorem 4: The uncontrolled inventory (that is: if it is unchecked with the documents of the corresponding economic events) does not prove the unfaulity of the uncontrolled bookkeeping<sup>75</sup> and with its data made balance sheet (2./T<sub>4</sub>).

Let us have the opposite of the theorem:

T<sub>4</sub>' : The uncontrolled inventory (that is: if it is unchecked with the documents of the corresponding economic events) **prove** the unfaulity of the uncontrolled bookkeeping and with its data made balance sheet.

1) Let us suppose that 10 pieces barrows, as current assets, perform, near many other, in a builder's bookkeeping registration and by it compiled balance sheet in 10x monetary value. But at stock-taking the employed of builder found 11 pieces barrows clearly in 11x monetary value. However, nobody did not check the data of the inventory, that is nobody did not compare with the data of the base documents the data of inventory, but the bookkeeping's data nor. That is e.g. nobody did not compare the data of the barrow-shopping documents with the data of inventory and bookkeeping.

The following question arises: Which data is real certainly? Is the data of the bookkeeping and by it compiled balance sheet or the corresponding data of the inventory real?

We can not prove nor confute the authenticity of the bookkeeping and balance sheet by the formulas  $A=C$  and/or  $\sum Dt = \sum Cr$  because both are not able on the target of check (by 2./A<sub>5</sub>).

That dilemma without checking is undefinable that the data of the bookkeeping and the balance sheet are unfaulity or not (by 2./A<sub>3</sub>). For example: the data of bookkeeping or the balance sheet can unreal if the accountant misprizes the number of pieces at bookkeeping, or if the booked invoice's quantity and monetary value data for the data of the thing's takeover justifying parcel bill is mistaken; and the assign did not observe this ones for did not checked them.

But it is possible that the data of the bookkeeping and the balance sheet are real however the corresponding data of the inventory are faulty. For example: if the employed, who takes stock, badly sums the numbers of the barrows, and writes 11 pieces for 10 and so the 11 was multiplied by x. Or the employed wrote for inattention the 11 for 10. But it is also possible that, if there were not inventorial identifiers on the barrows, on the seat of builder firm the lonely barrow of the fence-repairman also was added to

---

<sup>75</sup> That is clear that here the concord of the bookkeeping's data with the reality is not verified by the documents else it would be unnecessary that we verify those by the inventory.

the 10. So: the unfaulty of the inventory data, without their checking, neither may not prove nor may not confute. This problem without checking is undefinable (by 2./A<sub>4</sub>).

However these facts already contradict to T<sub>4</sub>' hence this theorem (2./T<sub>4</sub>) is true.

2) We may use also these arguments then if both the bookkeeping with the balance sheet together and the inventory contain 10 barrows and its 10x monetary value, but neither the bookkeeping nor the inventory are not controlled, that is: both are not fulcrate with base documents. Only now we do not know that the conformity really holds or not, this one holds for same cause as in the case 1). So: **neither may not prove nor may not confute the conformity. This problem without checking is undefinable** (2./A<sub>3</sub>, 2./A<sub>4</sub>). This fact also contradict to T<sub>4</sub>' hence this theorem (2./T<sub>4</sub>) is true.

That is: the corresponding data of the uncontrolled bookkeeping/balance sheet and the uncontrolled inventory either differ [in case 1)] or square [in case 2)] the uncontrolled inventory neither does not prove nor does not confute the differing or the conformity.

Q.e.d.

P.: 2./T<sub>4</sub>/C<sub>1</sub>, C<sub>2</sub>.

C.: 2./A<sub>3</sub>, A<sub>4</sub>, A<sub>5</sub>.

Corollary 1: The uncontrolled (that is: with the document of the corresponding economic events and with the corresponding data of the controlled inventory unchecked) bookkeeping events (account items) do not confirm (that is do not prove) the bookkeeping registration and by its data made balance sheet authenticity (2./T<sub>4</sub>/C<sub>1</sub>).

P.:

C.: 2./A<sub>4</sub>.

Corollary 2: Let R<sub>i</sub>, R<sub>d</sub>, R<sub>b</sub>, R<sub>e</sub> denote on the straight the reality of on the same season relating inventory data, all document's data, all bookkeeping data and the all economic event's data. By itself neither the inventory's data (R<sub>i</sub>) nor to the inventory season corresponding data (R<sub>d</sub>) of the booked documents but yet the both together nor confirm the reality of the touched bookkeeping (R<sub>b</sub>) and balance sheet but only the following four equality all at once: **R<sub>e</sub>=R<sub>d</sub> and R<sub>d</sub>=R<sub>b</sub> and R<sub>b</sub>=R<sub>i</sub> and R<sub>e</sub>=R<sub>i</sub>** (2./T<sub>4</sub>/C<sub>2</sub>). This corollary is called **the law of "square control" of the bookkeeping**.

P.:

C.: 2./A<sub>4</sub>.

### Standardization and automatization

Theorem 5: We can squarely assign a such finite set to any economist which consists its activity belonging from the standardized economic events (2./T<sub>5</sub>).

Let  $\mathcal{E}$  denote some economist, ' $\rightarrow$ ' the inherence and  $\mathbf{E}_a$  the set of such abstract economic events which's elements are specific for the activity of the economist  $\mathcal{E}$  and arose with the abstraction of the bookkeeping events. Let  $e_a$  denote these abstract economic events, hence  $e_a \in \mathbf{E}_a$  is holds. However let  $e_s$  denote the standard-

ized economic events and  $\mathbf{E}_s$  their finite set, that is:  $e_s \in \mathbf{E}_s$ . This time we can write this theorem with these notations thus too: (1)  $\mathcal{E} \rightarrow \mathbf{E}_s$ . Let us show that (1) is true.

By the axiom 2./A<sub>6</sub>: We can squarely assign a such finite set to any economist which consists from pair-wise different abstract economic events  $\mathbf{E}_a$  and this events are able on it that we define with them the possible changes of material position of the economist. But if we can squarely assign a so finite set to any economist then we can assign squarely to  $\mathcal{E}$  also, that is we may write: (2)  $\mathcal{E} \rightarrow \mathbf{E}_a$ .

However, by the relating definition: I name to **standardized economic events** (briefly only: to **standardized event**) those event-names that in the economist's bookkeeping **required to use** the concrete bookkeeping events on strictly name, by data-type a<sub>3</sub>. We constitute these events with standardization from the abstract economic events; and they all differ one from another formally (in view of the words or its the name's order or in view of the event's description) and by content (in view of the mean of the name or description of the event) too, *additionally their event coordinate n-tuple is clever, that is, real*. But  $e_s = e_a \in \mathbf{E}_a$  for this definition, hence  $\mathbf{E}_s \subseteq \mathbf{E}_a$  holds and then  $\mathcal{E} \rightarrow \mathbf{E}_s$  is true.

Q.e.d.

P.: 2./T<sub>5</sub>/C<sub>1</sub>, C<sub>2</sub>, 2./T<sub>7</sub>.

C.: 2./A<sub>5</sub>.

Corollary 1: Let n denote the number of the abstract economic events and k the number of the standardized economic events. On the relation of these holds:  $1 \leq k \leq n$  ( $n=1,2,\dots$ ) [2./T<sub>5</sub>/C<sub>1</sub>].

P.: 2./T<sub>6</sub>, 2./T<sub>7</sub>.

C.: 2./T<sub>5</sub>.

Corollary 2: The standardized economic events are also typical on the economist's activity, that is: they are economist-specific [2./T<sub>5</sub>/C<sub>2</sub>].

P.:

C.: 2./T<sub>5</sub>.

Theorem 6: In the (0;t] interval ( $t=1,2,\dots,M$ ) let concrete bookkeeping events occur that are named with standardized economic events. Let us classify these bookkeeping events by types of these standardized economic events. Thereafter let us sum these gross property changes that are occurred apropos of these bookkeeping events. This time the got algebraic sum, which belongs to the **M**th time-point, is equal with the main sum of classification (by types of these standardized economic events) of the gross property changes (2./T<sub>6</sub>).

In the (0;M] interval let them occur n pieces ( $n=1,2,\dots$ ) economist-specific economic events. Thus all time the measure of the gross property increases or decreases or only changes its structure (by A<sub>15</sub>). Let  $\mathbf{V}$  denote the measure of the gross property. Let us suppose that the measure data of the economist-specific bookkeeping event shows with the negative sign the decreases. Additionally, since the main sum  $\mathbf{V}$  of any classification of the gross property is invariant in point of compensatory (the opposite

sign but equal in size) changes of its two part sums (by  $1./T_{19}/C_1$ ), hence we can regard to zero the measure data of the compensatory changes.

With these conditions the measure data  $\mathbf{V}$  of the gross property in  $M$ th time-point is equal with the algebraic sum of same type measure data of in the  $(0;M]$  interval recorded  $n$  pieces economist-specific bookkeeping events (by  $1./T_{27}$ ). But we can name these  $n$  pieces economist-specific bookkeeping events with its corresponding standardized economic events, however hereof  $\mathbf{V}$  clearly is not changing.

The number of these standardized economic events is  $k$ , where  $1 \leq k \leq n$  ( $n=1,2,\dots$ ) [by  $2./T_5/C_1$ ].

Now, if  $k=n$  that is if the number of the standardized economic events and the number of the bookkeeping events are identical, this theorem is clearly true.

However if  $1 < k < n$  then let us decompose the summation onto  $k$  pieces of group by the type of the standardized economic events. Finally let us sum the algebraic sums of these groups, but this operate does not modify the value of  $\mathbf{V}$  for the associativity of the summation (by  $2./T_6$ ).

Q.e.d.

P.:

C.:  $1./T_{19}/C_1, T_{27}, A_{15}, 2./T_5/C_1$ .

**Theorem 7:** We can assign squarely to all *standardized* economic event the to it corresponding to concrete bookkeeping event belonging event coordinates' data-vector  $\underline{y}'^* = \underline{o}^*$  as meta data of the class-coherence [in the traditional bookkeeping it is called: to debit-credit account coherence] ( $2./T_7$ ).

Let  $\underline{y}'^* = \underline{o}^*$  denote the data-vector of some bookkeeping event which is same with the data  $a_4$  of this bookkeeping event.

The economic events' to changed part sum, within time classes, belonging final property classes and its change character marked data (that is the event-name or event-description) and the data-vector of the event coordinates mutually and squarely correspond to one another by their meaning (for  $A_{14}$ ). From this one and from the theorem  $2./T_1$  it follows that all standardized economic event which is used to name some concrete bookkeeping event coordinates' data-vector  $\underline{y}'^* = \underline{o}^*$  as meta data of the class-coherence

**Corollary:** To all standardized economic event may be squarely to assign all such concrete data of to them corresponding concrete documented economic event what depend from these standardized economic event ( $2./T_7/C$ ).

Q.e.d.

P.:

C.:  $2./T_7$ .

Theorem 8: The coordinates of some bookkeeping event of the economist may define automatically like the function of the economist-specific standardized economic events. (2./T<sub>8</sub>).

Let  $e_i$  denote the  $i$ th economist-specific [2./T<sub>5</sub>/C<sub>2</sub>] standardised economic events ( $i=1,2,\dots,n$ ). We can assign squarely to all *standardized* economic event the to it corresponding to concrete bookkeeping event belonging event coordinates' data-vector  $\underline{y}'^* = \underline{o}^*$  as meta data of the class-coherence [in the traditional bookkeeping it is called: to debit-credit account coherence] (2./T<sub>7</sub>). But  $\underline{y}'^* = \underline{o}^*$  is the value of the bookkeeping derivative<sup>76</sup>  $\underline{y}_i'^* = [y_1, y_2, \dots, y_k]_i' = \underline{o}_i^* = \phi'(x_i)$  in the position  $x_i = e_i$ .

Now the Mealy's event-coordinate designator automaton  $\underline{y}_i'^* = [y_1, y_2, \dots, y_k]_i' = \underline{o}_i^* = \phi'(x_i) = f'(e_i)$  automatically defines the  $\underline{y}'^* = \underline{o}^*$  as the value of the bookkeeping derivative in the position  $x_i = e_i$  with the function  $\phi'(x_i)$  or  $f'(e_i)$  by definition.

Q.e.d.

P.: 2./T<sub>8</sub>/C.

C.: 2./T<sub>7</sub>, 2./T<sub>5</sub>/C<sub>2</sub>.

Corollary: If the  $e_i \rightarrow \underline{y}_i'^* = [y_1, y_2, \dots, y_k]_i' = \underline{o}_i^*$  is all for  $i$  correctly predefined then the class-coherent of any and any number of documented economic or rather bookkeeping events will be unfaulty when we give with event-coordinate designator automaton. That is if all event-coordinate designation unfaulty for all  $e_i$  then the use of the event-coordinate designator automaton excepts the faults of the event-coordinate designation. This one isolate the bookkeeping system from this type of the fault, for any  $e_i$  and all the same that how many times we repeat this operate. (2./T<sub>8</sub>/C).

P.:

C.: 2./T<sub>8</sub>.

Theorem 9: The data of some bookkeeping event of the economist may define automatically like the function of data pf the economist-specific standardized economic events and the concrete documented economic events with bookkeeping automaton (2./T<sub>9</sub>).

The bookkeeping automaton is such complex real automaton which is modeled with more different simple Mealy's automaton. This one give automatically the class coherence data in function of standardized economic events (2./T<sub>7</sub>) just as all such data which depends from standardized economic event  $e_i$  ( $i=1,2,\dots,n$ ) (2./T<sub>7</sub>/C). It may be so data as for example the measure-unit or the per cent of the value added tax (VAT) or the VAT's suggested<sup>77</sup> sum, etc. The output data of the bookkeeping automaton may be yet the concrete data of the concrete documented economic events too. For example these are the date of event, the identification of the document, the quantity, the monetary value, etc. These will be output-data also in one block.

<sup>76</sup> Let us keep clear of blasphemy's show too! Hence I draw attention to following facts: (1) A bookkeeping derivative comparable with the mathematical derivative because in both cases there is all information in  $f(x)$  which relates on  $f'(x)$  and both come from  $f(x)$  with logical deduction instead of count. (2) Not only mathematical derivative exists. There is for example grammatical derivative (derivative word) and electrotechnical derivative (derivative circuit /branch-circuit) and ballistic derivative (ballistic path-deviation) too.

<sup>77</sup> The VAT's sum expediently may be only suggested because the transaction may be VAT-free too. This time the VAT's sum must be zero.

Q.e.d.

P.: 2./T<sub>10</sub>

C.: 2./T<sub>7</sub>, 2./T<sub>7</sub>/C.

Theorem10: The data of the (trial balance) cumulative statement what as the data of the A or C-aspect and the identification sign  $\mathbf{s}_j \in \mathbf{S} = \{s_1, s_2, \dots, s_i, \dots, s_p\}$  property's type (traditionally these called to ledger's accounts) may define with cumulative statement maker (trial balance query) automaton made from the data-base (2./T<sub>10</sub>).

The A and C-aspect classifications and the all identification sign  $\mathbf{s}_i \in \mathbf{S} = \{s_1, s_2, \dots, s_i, \dots, s_p\}$  property's type (traditionally these called to accounts of the ledger) and the part sums of these as the data of a (trial balance) cumulative statement can query automatically with cumulative statement maker (trial balance query) automaton from the bookkeeping data-base, which made with bookkeeping automaton by 2./T<sub>9</sub>. Namely the real version of the cumulative statement maker (trial balance query) abstract automaton is a such sequential machine which in sequent define by the input signs  $s_1, s_2, \dots, s_i, \dots, s_p$  marked traffic and balance data of the property's type (traditionally these are the ledger's accounts) just as it orders these in a cumulative statement (in a trial balance).

Q.e.d.

P.: 2./T<sub>10</sub>/C<sub>1</sub>,

C.: 2./T<sub>9</sub>.

Corollary 1: We may make the balance sheet also with the cumulative statement maker (trial balance query) automaton from the bookkeeping database if we correspondently complete this automaton (2./T<sub>10</sub>/C<sub>1</sub>).

P.:

C.: 2./T<sub>10</sub>.

Corollary 2: If the property classification system is N-aspect ( $N \geq 2$ ) we can make then also the cumulative statement (trial balance) and/or the balance sheet if we correspondently complete automaton (2./T<sub>10</sub>/C<sub>2</sub>).

P.:

C.: 2./T<sub>10</sub>.

Corollary 3: For the use of the bookkeeping and the cumulative statement maker (trial balance query) automaton is unnecessary to make and to keep with computer or hand the traditionally ledger's accounts. Ergo the account theories in this situation are reason lost. ***This situation is the death of the account theories*** (2./T<sub>10</sub>/C<sub>3</sub>).

P.:

C.: 2./T<sub>10</sub>.

### 3. The base elements of theory<sup>78</sup> of the debit and circle-debit

#### 3.1 Principles

##### 3.11 Definitions

1.  $N$  economists ( $n \geq 2$ ) make **debtor-circle** that is they **owe in circle** if and only if all owe at least to another one and claim also at least from another one.
2. We name the economist if it performs in the debtor-circle to **member of the debtor-circle**.
3. We say from the two member debtor-circle that it is **debtor-pair**.
4. **Simple debtor-circle** is that to which all members owe only single to other member and claim from only another one. The debtor-pair is simple debtor-circle.
5. **Complex debtor-circle** is such  $n$ -member ( $n \geq 3$ ) debtor-circle the members of which make two or more simple debtor-circle.
6. We name the economists to **performers of the market** if they sell and/or buy on the market.<sup>79</sup>
7. We name to **market segment** the subset of that set which stand  $n$  number performers of the market ( $n \geq 3$ ) and make a debtor-circle.
8. **Two market segments are independent** from one another if between its members there is no such one which owes to some member of the other segment.

##### 3.12 Market axioms

1. There are at least two performers on all markets, that is: there is at least a seller and at least a buyer.  
P.: 3./ $T_2, T_3$ .
2. The performers of the market apropos of the traffic always sell away the object of the own property as seller or rather they give that one as quid pro quo if they are buyers<sup>80</sup>.  
P.: 3./ $T_2$ .

#### 3.2 The theorems of the debit and circle-debit and its proofs

Theorem 1: All creditors are simultaneously debtors too (3./ $T_1$ ).

Let  $G_1$  be one of the existent creditors and let it credit e.g. to the economist  $G_0$ . Let us show that like  $G_1$  so all creditors are simultaneously debtors too.

---

<sup>78</sup> This theory is a branching of the property theory.

<sup>79</sup> Under on the market seller and buyer economist I do not understand the applied or the commissioned of the economist if they act instead of economist. But if the applied or the commissioned sells its work-force or rather the service to the employer/mandatory then they and its employer/mandatory also sell the own belongings.

<sup>80</sup> The **middleman** also its own service sells away in return for poundage. The **commission-agent** also sells the goods as own belongings because after the selling buys that from the original owner.

If  $G_1$  is creditor of  $G_0$  then  $G_0$  owes to  $G_1$  by  $1./A_9$  and hence  $G_1$  is a man of property by  $1./A_8$ . (Let  $V_1$  denote the property of  $G_1$ , where  $V_1 > 0$  by  $1./T_1$ .) But then  $G_1$  has debt also because whom has property it has debt also by  $1./A_8$ . (Let  $A_1$  denote the debt of  $G_1$ , where  $A_1 > 0$  by  $1./T_2$ .) Thus the next statement hold true:  $(V_1 > 0) \rightarrow (A_1 > 0)$  by  $1./A_8$  and  $1./T_1, T_2$ . Consequently it must be that let  $G_1$  owes one or more to somebody that is either to  $G_0$  or other to economist(s) e.g. to  $G_2$ . Ergo  $G_1$  is debtor itself too. Since  $G_1$  may be any one of creditors (that it is debtor it follow thereout that it in one block creditor by  $1./A_8$ ) hence the following statement is true: all creditors are simultaneously debtors too.

Q.e.d.

P.:  $3./T_3$ .

C.:  $1./A_8, A_9, T_1, T_2$ .

**Theorem 2:** The performers of the market are all economists of property ( $3./T_2$ ).

Let us choose out arbitrary two of the performers of the market. Let them be  $G_1$  and  $G_2$ . This time for example let  $G_1$  seller whilst  $G_2$  buyer by  $3./A_1$ . I have:  $G_1$  and  $G_2$  are economists of property as either of others.

If namely not then: or  $G_1$  as seller do not sells away the own property's object or  $G_2$  as buyer do not give across as the quid pro quo of the own property's object or neither of them give the own property's object in the transaction to the other one. But these three case contradict to  $3./A_2$  because by  $3./A_2$ : "The performers of the market apropos of the traffic always sell away the object of the own property as seller or rather they give that one as quid pro quo if they are buyers." Thus  $G_1$  and  $G_2$  propertied may be only. If however  $G_2$  is the seller and  $G_1$  is the buyer, they are then also propertied performers of the market sithence this time we transpose only the indexes of  $G_s$ .

Finally: since we may choose of the all market performers arbitrary two to  $G_1$  and  $G_2$  hence what statement is true in case of  $G_1$  and  $G_2$  that is true in case of the all market performers too.

Q.e.d.

P.:  $3./T_3, T_4$ .

C.:  $3./A_1, A_2$ .

**Corollary:** All seller is buyer also and vice versa ( $3./T_2/C$ ).

P.:

C.:  $3./T_2$ .

**Theorem 3:** If there are only two economists of property on a market then they owe only to one another. This time they, as debtor-pair, make that debtor-circle to which is minimal the number of its members. This one is the minimal case of the circle-debit. ( $3./T_3$ ).

There are at least two performer on all market (by 3./A<sub>1</sub>) and they are economists of the property (by 3./T<sub>2</sub>). Thus let two performers be only now on the market; they are G<sub>1</sub> and G<sub>2</sub>. Let us show that G<sub>1</sub> and G<sub>2</sub> owe only to one another.

Since G<sub>1</sub> has property hence G<sub>1</sub> has debt (by 1.A<sub>1</sub>) and thus G<sub>1</sub> has creditor too (for 1./A<sub>9</sub>). This creditor can not be only G<sub>2</sub> by the condition. But if G<sub>2</sub> is creditor then G<sub>2</sub> has property (by 1./A<sub>9</sub>) and hence G<sub>2</sub> has debt (by 1.A<sub>1</sub>) just as thus G<sub>2</sub> has creditor too (for 1./A<sub>9</sub>). However this creditor can not be only G<sub>1</sub> by the condition.

G<sub>1</sub> and G<sub>2</sub> thus owe only to one another. This one is the minimal case of the circle-debit (3./T<sub>3</sub>).

Q.e.d.

P.: 3./T<sub>4</sub>.

C.: 1./A<sub>8</sub>, A<sub>9</sub>; 3./A<sub>1</sub>, T<sub>1</sub>, T<sub>2</sub>.

**Theorem 4:** There is circle-debit on all market that is: the circle-debit is the attribute of the markets other their essential feature (3./T<sub>4</sub>).

Let  $n$  denote the number of the market performers. Let there be  $n$  market performers ( $n \geq 2$ ) on the examined market. I have that there is circle-debit on this market and on all markets, consequently the circle-debit is natural and essential feature that is attribute of the markets. Hence we must show that there is at least a debtor-circle on the  $n$ -performers market ( $n \geq 2$ ).

There is  $n$  performers ( $n \geq 2$ ) on this examined market. These are all economists of property.

If  $n=2$  that is there is only two performer of this market then these two as debtor-pair make a minimal member debtor-circle. This time the theorem is true. Whereas this market is not specified in other interrelation hence it also is true statement that there is circle-debit on all two-performer market.

Now let us show that there is on this market debtor-circle that is circle-debit if  $n > 2$ . We can apply to this the following method too:

- 1) We choose random a member of the  $n$ -performers market ( $n \geq 2$ ) and assign the sequential number 1.
- 2) Then we choose again random a member of leftover and assign the next sequential number.
- 3) After this we govern an arrow with its peak to the greater sequential number. This arrow means that the performer whom the sequential number is smaller and it has property (by 3./T<sub>2</sub>) owe to that the sequential number is greater. Namely this later is the creditor of the previous because: whom has property it has debt also and with it owe its creditor (by 1./A<sub>8</sub> és 1./A<sub>9</sub>).
- 4) We repeat the steps 2) and 3) as long as there is unnumbered member. After this already an arrow governs from the ( $n-1$ )th

member to the  $n$ th member too. Whereas all market performers have property so the  $n$ th performer has also and hence it also has debt (by  $1./A_8$ ) with which it owes to its creditor (by  $1./A_9$ ).

- 5) Since there is no already unnumbered member hence the  $n$ th member must owes or to  $1^{\text{st}}$  and/or  $2^{\text{nd}}$  ... and/or  $(n-1)$ th member. The sign of this debit is that arrow governs from the  $n$ th member to the one or more others.

All this denotes that there is at least a debtor-circle on this market to which has  $n$  or  $n-1$  or ... 3 or 2 members.

Whereas this market is not specified in other interrelation hence it is true statement that there is circle-debit on all market and this is the attribute of the markets ( $3./T_4$ ).

Q.e.d.

P.:

C.:  $1./A_8, A_9; 3./T_2, T_3$ .

Corollary 1: If there is such debtor-circle on the  $n$ -performer market ( $n \geq 3$ ) which is not debtor-pair then any member of so debtor-circle may owes not only to one other circle-member. Thus such debtor-circle may be complex too ( $3./T_4/C_1$ ).

Q.e.d.

P.:

C.:  $3./T_4$ .

Corollary 2: Let  $P$  denote the number of the debtor-pair. The  $n$ -performer market (where  $n \geq 3$ ) may contain more debtor-pair also. The possible maximal number  $P_{\max}$  of the debtor-pairs  $P_{\max} = [(n-1)*n]/2$  what is equivalent e.g. with number of that lines what connect apexes of a convex  $n$ -angle (where  $n \geq 3$ ).  $P_{\max} = [(n-1)*n]/2$  may verify easy with mathematical induction. [ $3./T_4/C_2$ ].

Q.e.d.

P.:

C.:  $3./T_4$ .

Corollary 3: If the  $n$ -performer market (where  $n > 3$  and even), as a set, disintegrates on number  $k$  of market-segments (that is on subsets) where  $n=2k$  then it may contains pieces  $k$  from one another independent debtor-pairs ( $3./T_4/C_3$ ).

Q.e.d.

P.:

C.:  $3./T_4$ .

Corollary 4: If the  $n$ -performer market (where  $n > 2$ ) disintegrates on market-segments then it may contains debtor-pair(s) and/or debtor-circle(s) with odd member ( $3./T_4/C_3$ ).

Q.e.d.

P.:

C.:  $3./T_4$ .

## Preface to appendixes

Though main theme what we discuss in this book is the bookkeeping of the property, still I recommend the following theme, which follows from theory system in this book written, in the note of readership:

The individual bookkeepings may have differential objects. For example: the losing team keeps the books its thrashing; the football-umpire keeps the books the distributed yellow and red cards; the pedagogue books the grade of student; the historian books the events of the history; the biologist books the results of the research; the economist's accountant in turn books the data of the changes, that is the data of the economic events, what occurred in the property and/or debit apropos of the economy. Thos ones thus are all events of chronologic registrations that is bookkeepings namely special bookkeepings.

Special bookkeepings are thus for example:

- a) bookkeeping of grades of the students or other change of the knowledge-level in school-book or lecture book;
- b) bookkeeping of phone-costs of the families or enterprises by caller and called and/or cellular and lined phone, etc.;
- c) bookkeeping of licence holder of the television, the telephone, the news or the internet service;
- d) bookkeeping of the library, the Land Registry, the register of births, the changes of the population the vehicles-stores; or rather
- e) bookkeeping of chronological data-lines of police, prosecution, tax office, etc.;
- f) bookkeeping of the documents of litigations such as petitions, negotiations, surveys, minute-books, orders, decisions, etc.;
- g) bookkeeping of the data-lines of state statistics, for example: bookkeeping of the GDP's changes;
- h) bookkeeping of morphosis of prices of stock market goods;
- i) bookkeeping of data of the natural or technical events as for example: bookkeeping of data of meteorological, astronomical observations or technical, biological, chemical experiments;
- j) bookkeeping in the economy e.g. registering of orders, projects, publicity, marketing, labour and wage;
- k) bookkeeping of the material and product-stock separately from the property bookkeeping; the bookkeeping of the first cost, etc.

I will show three well illustrating examples on the special bookkeepings in the following three appendixes, whilst this ones are fictive.

## Appendix 1

### ***Bookkeeping of property and its balance sheet***

The table y1 below shows a n=4 that is time-assets and time-capitals aspect dynamic just as assets and capitals aspect static complex balance sheet of the property which is defined squarely in the table y2 visible by bookkeeping database of the property.

#### ***4 aspect complex dynamic and static balance sheet***

Time-assets dynamic classification												Static classification	
1	2	4									5		
Assets- types	a	Times (days)										a(i)s	
		0	1	2	3	4	5	6	7	8	9		
Sheep	1	1 000	10	-10								1 000	6
Cow	2	2 000										-1 000	1 000
Feed	3									600			600
Claims from buyers	4	300			-200							700	800
Gold money	5				200		50	150	1 100	-600	700		1 600
p(t)		3 300	10	-10	0	0	50	150	1 100	0	400		5 000
Cumulated p(t)		3 300	3 310	3 300	3 300	3 300	3 350	3 500	4 600	4 600	5 000		7

Time-capitals dynamic classification												Static classification	
1	2	4									5		
Capitals- types	c	Times (days)										c(j)s	
		0	1	2	3	4	5	6	7	8	9		
Cumulative result	1	2 700											2 700
Services income	2						50	150					200
Revenue	3										1 400		1 400
Wagework revenue	4								1 100				1 100
Accretion	5		10										10
Labour cost	6											-100	-100
Goods cost	7											-1 000	-1 000
Long-term liabilities	8	500				50							550
Current liabilities	9	100		-10		-50					100		140
Opener balance	10												0
p(t)		3 300	10	-10	0	0	50	150	1 100	0	400		5 000

table y1

**Bookkeeping registration (database)**

1	2	3	4	5
Time-point	The name (description) of bookkeeping event	Event-coordinates		Sum (gold)
(Day)		(D)	(Cr)	
	<b>Opening of assets:</b>			
0.	1. Opening of sheep-stores	1a	10c	1 000
0.	2. Opening of cow-stores	2a	10c	2 000
0.	3. Opening of cleims	4a	10c	300
	<b>Opening of capitals:</b>			
0.	4. Opening of cumulated result	10c	1c	2 700
0.	5. Opening of long-term liabelities	10c	8c	500
0.	6. Opening of current liabilities	10c	9c	100
	<b>Current economic events:</b>			
1.	7. Account of the sheep-accretion	1a	5c	10
2.	8. Extinction of the sheep-debt in nature	-1a	-9c	10
3.	9. Payment of claim in cash (gold money)	5a	-4a	200
4.	10. Across class of the current liability on long-term	8c	-9c	50
5.	11. Service income in cash	5a	2c	50
6.	12. Service income in cash	5a	2c	150
7.	13. Wagework revenue in cash	5a	4c	1100
8.	14. Shopping of the feed in cash	3a	-5a	600
9.	15. Sale income of one cow for cash	5a	3c	700
9.	16. Cost of two sold cows	-2a	-7c	1000
9.	17. Sale income of one cow in credit	4a	3c	700
9.	18 Account of payment of labour as cost and as liability	9c	-6c	100

**table y2**

TIME-ASSETS-ASPECT CUMULATIVE CLASSIFICATION											ASSETS STATIC CLF.	
Asset-types	Time-points (days)										$\Sigma a(i)$	
	0	1	2	3	4	5	6	7	8	9		
Sheep	1 000	1 010	1 000	1 000	1 000	1 000	1 000	1 000	1 000	1 000	1 000	1 000
Cow	2 000	2 000	2 000	2 000	2 000	2 000	2 000	2 000	2 000	2 000	1 000	1 000
Feed	0	0	0	0	0	0	0	0	0	600	600	600
Claims from buyers	300	300	300	100	100	100	100	100	100	100	800	800
Gold money	0	0	0	200	200	250	400	1 500	900	1 600	1 600	1 600
<b>total property</b>	<b>3 300</b>	<b>3 310</b>	<b>3 300</b>	<b>3 300</b>	<b>3 300</b>	<b>3 350</b>	<b>3 500</b>	<b>4 600</b>	<b>4 600</b>	<b>5 000</b>	<b>5 000</b>	<b>5 000</b>

TIME-CAPITALS-ASPECT CUMULATIVE CLASSIFICATION											CAPITALS STATIC CLF.	
Capita-types	Time-points (days)										$\Sigma c(j)$	
	0	1	2	3	4	5	6	7	8	9		
Cumulative result	2 700	2 700	2 700	2 700	2 700	2 700	2 700	2 700	2 700	2 700	2 700	2 700
Services income	0	0	0	0	0	50	200	200	200	200	200	200
Revenue	0	0	0	0	0	0	0	0	0	1 400	1 400	1 400
Wagework revenue	0	0	0	0	0	0	0	1 100	1 100	1 100	1 100	1 100
Accretion	0	10	10	10	10	10	10	10	10	10	10	10
Labour cost	0	0	0	0	0	0	0	0	0	0	-100	-100
Goods cost	0	0	0	0	0	0	0	0	0	0	-1 000	-1 000
Long-term liabilities	500	500	500	500	550	550	550	550	550	550	550	550
Current liabilities	100	100	90	90	40	40	40	40	40	140	140	140
Opener balance	0	0	0	0	0	0	0	0	0	0	0	0
<b>total property</b>	<b>3 300</b>	<b>3 310</b>	<b>3 300</b>	<b>3 300</b>	<b>3 300</b>	<b>3 350</b>	<b>3 500</b>	<b>4 600</b>	<b>4 600</b>	<b>5 000</b>	<b>5 000</b>	<b>5 000</b>

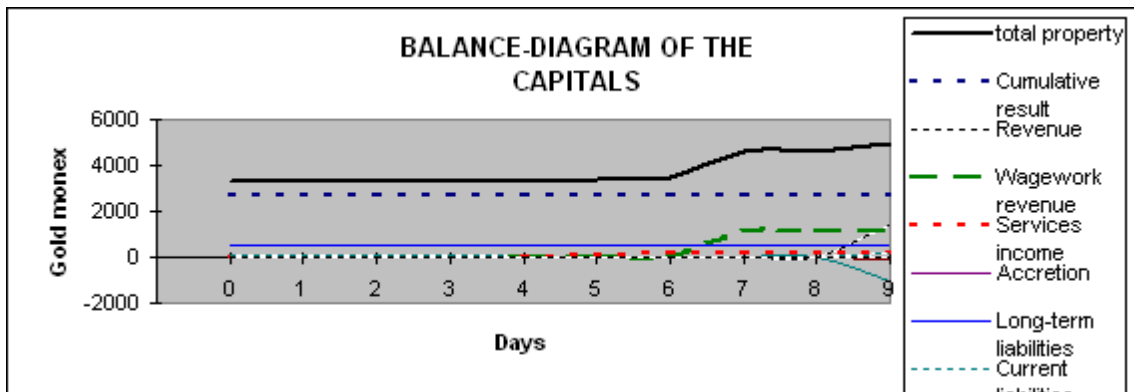
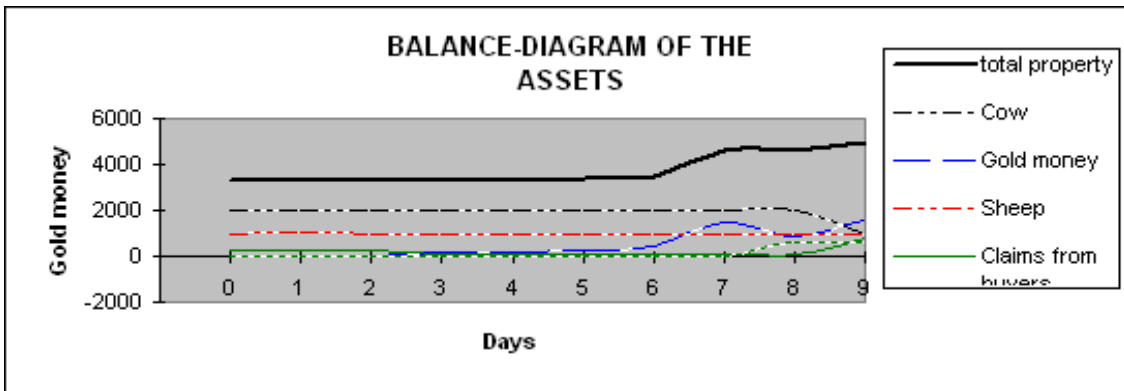

## Appendix 2

### **Bookkeeping of level of knowledge of the students and the knowledge balance sheet**

The data of data-base of the bookkeeping define (see in the table t4) the balance sheets in the table t1, t2 and t3. A composite static and dynamic balance sheet version below is visible in the table t1. The balance sheet by t3 contains the known school report of the student in the first two columns.

**STATIC and DYNAMIC (composite) KNOWLEDGE BALANCE SHEET**

Students		Average knowledge-level	Subjects		Average knowledge-level	Months		Average knowledge-level
1	Benedict Jacob	3	1	Mathematics	2	1	January	5
2	Peter Smith	3,5	2	Physics	3	2	February	4
3	Mary Gross	4	3	Literature	4	3	March	2,5
			4	History	5			
		3,5			3,5			3,5

Table t1

**STATIC KNOWLEDGE BALANCE SHEET**

Students		Average knowledge-level	Subjects		Average knowledge-level
1	Benedict Jacob	3	1	Mathematics	2
2	Peter Smith	3,5	2	Physics	3
3	Mary Gross	4	3	Literature	4
			4	History	5
		3,5			3,5

Table t2

**STATIC STUDENT- SUBJECT KNOWLEDGE BALANCE SHEET**

Students		Average knowledge-level	Subject of students		Average knowledge-level	Subjects		Average knowledge-level
1		2		3				
1	Benedict Jacob	3	11	Mathematics		1	Mathematics	2
			12	Physics	3	2	Physics	3
			13	Literature		3	Literature	4
			14	History		4	History	5
2	Peter Smith	3,5	21	Mathematics	2			
			22	Physics				
			23	Literature				
			24	History	5			
3	Mary Gross	4	31	Mathematics				
			32	Physics				
			33	Literature	4			
			34	History				
		3,5			3,5			3,5

Table t3

The grade book, as bookkeeping, defines the data of the previous balance sheets and its form may be the following too:

**Knowledge-bookkeeping's database (alias grade book)**

<b>GRADE BOOK OF CLASS 1/A</b>				
Change of knowledge-level of the student				
Event's time-point	Event's Description	Event-coordinates		Event's numerical value (grade)
		Student's identifier-number	Subject's identifier-number	
data <sub>1</sub>	data <sub>2</sub>	data <sub>3</sub> *		data <sub>4</sub>
		y <sub>1</sub>	y <sub>2</sub>	
10.01.2010	<b>Peter Smith</b> answered from history	2	4	5
11.02.2010	<b>Mary Gross</b> answered from literature	3	3	4
18.03.2010	<b>Peter Smith</b> answered from mathematics	2	1	2
20.03.2010	<b>Benedict Jacob</b> wrote school exercise from physics	1	2	3

\* The **data<sub>3</sub>** is same with two elements  $y_1$  and  $y_2$  of the vector  $y=[y_1, y_2]^*$  of the event-coordinates

**Table t4**

Same time the bookkeeping of the knowledge-level happen a "grade book" of the total school too. This time clearly expedient if we record for example in the book the identity of the years (as the 5<sup>th</sup> data) and/or the identity of the classes (as the 6<sup>th</sup> data) and/or the identity of the teachers (as the 7<sup>th</sup> data). The aspect-number of the balance sheet may be this time as good 7 too; and this time we may show the conformation of the knowledge-level of the students by the teachers. This information is well usable for the managers of the schools.

### Appendix 3

## Bookkeeping of the monthly telephone-cost and the monthly cost balance sheet

#### 4 ASPECT

#### STATIC and DYNAMIC MONTHLY TELEPHONE COST BALANCE SHEET

Caller number	Phone cost \$	Called number	Phone cost \$	Called cellular or wire phone	Phone cost \$	Call times	Phone cost \$
1 4010246 G1	2640	1 6308708 G	1056	1 Cellular phone	870	1 10.01.2010	650
2 4010247 G2	1056	2 3424479 H	10	2 Wire phone	2951	2 11.01.2010	1066
3 4010248 G3	125	3 30 6649984	70			3 12.01.2010	920
		4 4323900 M	12			4 13.01.2010	0
			5			5 14.01.2010	0
						6 15.01.2010	125
						7 16.01.2010	870
						8 17.01.2010	0
						9 18.01.2010	200
<b>Total sum</b>	<b>3821</b>	<b>Total sum</b>	<b>3821</b>	<b>Total s.</b>	<b>3821</b>	<b>Total sum</b>	<b>3831</b>

table f1

#### Monthly telephone-cost's bookkeeping database

LIST OF CALLS						
Call's time	Description of the calls	Event-coordinates			Phone costs \$	
		Caller n.	Called n.	Called cell. or wire phone		
data <sub>1</sub>	data <sub>2</sub>	data <sub>3</sub> *			data <sub>4</sub>	
		y <sub>1</sub>	y <sub>2</sub>	y <sub>3</sub>		
10.01.2010	4010246 G1 called 3424479 H	1	2	2	650	
11.01.2010	4010247 G2 called 6308708 G	2	1	2	1066	
12.01.2010	4010246 G1 called 3424479 H	1	2	2	920	
15.01.2010	4010248 G3 called 4323900 M	3	4	2	125	
16.01.2010	4010246 G1 called 30 6649984	1	3	1	870	
18.01.2010	4010246 G1 called 30 6649984	1	3	2	200	
Total sum::					<b>3831</b>	

\* The data<sub>3</sub> is same with three elements y<sub>1</sub>, y<sub>2</sub> and y<sub>3</sub> of the vector  $y=[y_1, y_2, y_3]^*$  of the event-coordinates

table f2

## Appendix 4

### *An to day used hungarian, english, and a german classic balance sheet of property*

#### KLASSZIKUS VAGYONMÉRLEG

(V<sub>BR</sub>)

Eszközök (Aktívák)	Források, vagy Tőke (Passzívák)
<b>A. Befektetett eszközök</b>	<b>D. Saját forrás (vagy saját tőke)</b>
Immateriális javak (vagyon értékű jogok)	Jegyzett tőke vagy alapítói tőke
Tárgyeszközök (telek, épület, gép, berendezés)	Tőketartalék
Tartós pénzügyi befektetések	Eredménytartalék
Beruházások (épület, gép, stb.)	Előző évek áthozott vesztesége
<b>B. Forgóeszközök</b>	Mérleg szerinti (tárgyidőszak) eredmény: [(+) nyereség v. (-) veszteség]
Készletek (anyag, áru, stb.)	<b>E. Céltartalékok</b>
Követelések (vevőktől, állantól, stb)	<b>F. Idegen forrás (vagy idegen tőke)</b>
Értékpapírok (forgatási célú)	Hosszúlejáratú kötelezettségek
Pénzeszközök (bankszámlapénz, készpénz)	Rövidlejáratú kötelezettségek
<b>C. Aktív időbeli elhatárolások</b>	<b>G. Passzív időbeli elhatárolások</b>
<b>Eszközök összesen (A)</b>	<b>Források összesen (P)</b>
<b>E=F (A=P)</b>	

hungarian

#### CLASSICAL PROPERTY BALANCE SHEET

(P<sub>GR</sub>)

Assets (Active)	Capitals (Passive)
<b>A. Current assets</b>	<b>A. Current liabilities</b>
Cash on hand in Banks	Accounts payable
Time deposits and short-term investments	Notes payable
Inventories	Customer deposits
Prepayments	Taxes payable
<b>B. Fixed assets</b>	Interest payable
Lands	<b>B. Long-term liabilities</b>
Buildings	Notes payable
Furniture and equipment	<b>C. EQUITY (other net property)</b>
Less: Accumulated depreciation	Retained earnings
<b>C. Other assets</b>	Memberships
<b>Total assets (A)</b>	<b>Total capitals (Equities and liabilities) (P)</b>
<b>A=P</b>	

english

## KLASSISCH VERMÖGEN-BILANZ

(V<sub>GR</sub>)

Aktiva	Passiva
<i>Form und Liquidität des Vermögens:</i>	<i>Herkunft und Fristigkeit der finanziellen Mittel:</i>
<b>A. Anlagevermögen (langfristig)</b>	<b>A. Eigenkapital</b>
I. Immaterielle Vermögensgegenstände	I. Gezeichnetes Kapital
II. Sachanlagen	II. Kapitalrücklage
III. Finanzanlagen	III. Gewinnrücklagen
<b>B. Umlaufvermögen (kurzfristig)</b>	IV. Gewinn-/Verlustvortrag
I. Vorräte (Roh-, Hilfs-, und Betriebsstoffe, usw.)	V. Jahresüberschuss/Jahresfehlbetrag
II. Forderungen und sonstige Vermögensgegenstände	<b>B. Rückstellungen</b>
III. Wertpapiere	<b>C. Verbindlichkeiten (Fremdkapital)</b>
IV. Flüssige Mittel (Schecks, Kassenbestand, Bank)	-(Langfristige Verbindlichkeiten (Schulden))
<b>C. Rechnungsabgrenzungsposten</b>	-(Kurzfristige Verbindlichkeiten (Schulden))
<b>Gesamtvermögen (A)</b>	<b>D. Rechnungsabgrenzungsposten</b>
<b>Gesamtvermögen (A)</b>	<b>Gesamtkapital (P)</b>
<b>A=P</b>	

**german**

## Appendix 5

### *The facts of experiment of a publication*

**1. E-mail** (2009. augusztus 31, hétfő, 4:29 PM)

**From:** Vida Krisztina [mailto:Vida.Krisztina@akkr.hu]  
**Sent:** Monday, August 31, 2009 4:29 PM  
**To:** 'gulyas@ginprofessional.hu'  
**Subject:** kapcsolatfelvétel/Akadémiai Kiadó  
**Importance:** High

Tisztelt Gulyás István!  
 Hivatkozással imént egyeztetésünkre küldök Önnek egy levelet.  
 Kérem, hogy kiadásra felajánlani kívánt művét válaszában szíveskedjék eljuttatni.  
 Köszönettel és üdvözlettel:

*Vida Krisztina*  
*Akadémiai Kiadó*  
*Tel.: 1/464-8254*  
*Fax: 1/464-8251*

**2. E-mail** (2009. augusztus 31, hétfő, 5:00 PM):

**From:** gulyas@ginprofessional.hu [mailto:gulyas@ginprofessional.hu]  
**Sent:** Monday, August 31, 2009 5:00 PM  
**To:** Vida Krisztina  
**Subject:** RE: kapcsolatfelvétel/Akadémiai Kiadó

Tisztelt Vida Krisztina!

Mellékeltem ajánlott, most elkészült könyvem online változatát PDF formátumban. Mint említettem a könyv a Modern Könyvvitel (2009) főcímet viseli. Közelebbről:

Gulyás István

## **MODERN KÖNYVVITELTAN**

***A modern  $n$ -szeres ( $n \geq 3$ ) vagyonskönyvvitel,***

*mint*

***az egyik speciális könyvvitel***

***elméletének elemei***

***és***

***axiomatikus rendszere***

***(a számlaelméletek halála)***

2009

A tartalomjegyzék és az előszó önmagáért beszél. Külön ismertető még itt olvasható:

[http://www.ginprofessional.hu/GI-A\\_modern\\_n-szeres\\_kvitel\\_20090814\\_01Rv\\_html-ben/N-szeres\\_kvitel\\_ajanl\\_2009\\_hu.html](http://www.ginprofessional.hu/GI-A_modern_n-szeres_kvitel_20090814_01Rv_html-ben/N-szeres_kvitel_ajanl_2009_hu.html) .

A könyvnek van már ISBN száma, a nevemen és a cégem nevén (ez csak a jogbiztonság okán van és nem jelenti azt, hogy magam óhajtom kiadni), továbbá letétbe van helyezve az Artisjus irodánál.

**Szerintem ilyen tartalommal a világon nem volt és nincs könyvvitelten. Ez a könyvvitelten új, mint például Einstein relativitáselmélete, vagy mint Bolyai abszolút geometriája az Appendixben. És Amint 2300 éve megalapozta Euklidész Elemek című műve az axiomatikus és deduktív geometriát, akként alapozza meg e könyv a könyvviteli elemek résszel a könyvviteltant és teszi több, mint 2000 év után - a matematikához hasonlóan - egzakt és deduktív - valódi - tudománnyá, a hagyományos könyvviteltankönyvek mintapéldáiból álló „receptgyűjteménye helyett”.** Emellett kontírozási algoritmussal segíti a gyakorló könyvelőket, és az absztrakt könyvelőautomata résszel pedig a könyvviteli szoftverek íróit. Tehát munkaeszköz is egyben! A 435 oldalból 300 népszerűsítő jelleggel íródott, a 300-435 oldal közötti rész a tudomány iránti igényt elégíti ki. Itt olvasható a könyvviteli elemek axiomatikus rendszere.

Várom mielőbbi válaszukat: érdekl-e Önöket e könyv bel- és külföldi kiadása.

Üdvözlettel:  
Gulyás István  
közgazdász

**3. E-mail** (2009. szeptember 03, csütörtök, 1:11 PM):

**From:** Fehér Katalin [mailto:Feher.Katalin@akkr.hu]  
**Sent:** Thursday, September 03, 2009 1:11 PM  
**To:** 'gulyas@ginprofessional.hu'  
**Subject:** RE: MODERN KÖNYVVITELTAN - ajánlat kiadásra

Tisztelt Gulyás István,  
köszönettel megkaptuk kéziratának elektronikus változatát.  
Kiadónk a témában tanácsadói rendszerrel dönt arról, hogy mely művek gondozása illeszkedik a kiadói profilba.

**Kérem szíves hozzájárulását ahhoz, hogy tanácsadóinknak továbbíthassuk az Ön által küldött levelet és kéziratot a döntés meghozatalához..**

Köszönettel és üdvözlettel,

Dr. Fehér Katalin PhD  
vezető szerkesztő  
Akadémiai Kiadó Zrt.  
1117 Budapest,  
Prielle Kornélia u. 19/D  
(1) 464 8274  
[www.akademiaikiado.hu](http://www.akademiaikiado.hu)

**4. E-mail** (2009. szeptember 03, csütörtök, 1:38 PM):

**From:** gulyas@ginprofessional.hu [mailto:gulyas@ginprofessional.hu]  
**Sent:** Thursday, September 03, 2009 1:38 PM  
**To:** Fehér Katalin  
**Subject:** RE: MODERN KÖNYVVITELTAN - ajánlat kiadásra

Tisztelt Dr. Fehér Katalin!

Köszönöm a visszaigazolást.

**A hozzájárulásomat természetesen megadom** - e procedúrával ugyanis eleve számoltam.

Üdvözlettel:

Gulyás István

**5. E-mail** (2009. szeptember 08, kedd, 10:49 AM):

**From:** GIN Professional Kft [mailto:ginprofessional@mail.datanet.hu] **On Behalf Of** [gulyas@ginprofessional.hu](mailto:gulyas@ginprofessional.hu)  
**Sent:** Tuesday, September 08, 2009 10:49 AM  
**To:** Fehér Katalin  
**Subject:** Javaslat matematikus tanácsadó bevonására

Dr. Fehér Katalin PhD  
 vezető szerkesztő  
 Akadémiai Kiadó Zrt.

Tisztelt Fehér Katalin!

A múlt hét csütörtökön folytatott telefonbeszélgetésünk alkalmával említette, hogy a kiadó, a könyvem esetleges gondozását illető döntéséhez, közgazdász tanácsadók véleményére fog támaszkodni.

Könyvem, bár tárgya szerint valóban a közgazdaságtan egyik ágával, a számvitel részét képező könyvviteltannel foglalkozik, azonban a tárgyalt vagyonszámvitelt - először a történelem folyamán - egzakt, deduktív (azaz: alap és definiált fogalmak, valamint axiómák alkalmazásával tételeket megfogalmazó és azokat bizonyító) tudománnyá teszi a „könyvviteli elemek” axiomatikus rendszerével (320-420. oldal). Következésképpen, ez utóbbi tény is tekintve, nem csak közgazdaságtudományi, hanem matematikai, ill. matematikai logikai tudományos mű is egyben.

Tekintettel arra, hogy ez idáig - a történelem folyamán - a könyvviteltanban az axiomatikus rendszereket a tudomány megalapozására sehol a világon nem alkalmazták, ezért (érthetően) a közgazdászokkal, ill. a közgazdász tudományos kutatókkal a képzésük során nem is ismertették azt meg. (Én magam is, mint közgazdász, autodidakta képeztem magam e témakörben.) Az axiomatikus rendszereket eleddig főképp (az arisztotelészi logikát és az elméleti fizika einsteini relativitáselméletét tekinthetjük ismert kivételnek) a matematika különféle ágainak megalapozására használták, úgymint a geometria, a halmazelmélet, a valószínűség számítás, a természetes számok peanoi elmélete, stb. Mindezek alapján úgy gondolom, hogy könyvem kiadói megítéléséhez az axiomatikus rendszerek terén kellő szakismerettel és jártassággal nem rendelkező közgazdász szakértők egymagukban nem valószínű, hogy autentikus véleményt tudnak mondani. Ezért - a Kiadó üzleti és a magam írói érdekét is szem előtt tartva - tisztelettel javasolom, hogy a könyv Akadémia Kiadói gondozásra alkalmas voltának megítéléséhez, a közgazdász tanácsadók mellett, az axiomatikus rendszerek terén kellő szakismerettel és jártassággal rendelkező (matematikus és/vagy logikai) szaktanácsadót is, ha tehetik, vegyenek igénybe.

Tisztelettel és üdvözlettel:

Gulyás István  
 közgazdász - matematikus

**6. E-mail** (2009. szeptember 08, kedd, 11:26 AM):

**From:** [Fehér Katalin](mailto:feher.katalin@akademiai.kiadoi.hu)  
**To:** '[gulyas@ginprofessional.hu](mailto:gulyas@ginprofessional.hu)'  
**Sent:** Tuesday, September 08, 2009 11:26 AM  
**Subject:** RE: Javaslat matematikus tanácsadó bevonására

Tisztelt Gulyás István, **köszönöm a hasznos információkat**, üdvözlettel, Katalin

Dr. Fehér Katalin PhD  
vezető szerkesztő  
Akadémiai Kiadó Zrt.  
1117 Budapest,  
Prielle Kornélia u. 19/D  
(1) 464 8274  
[www.akademiaikiado.hu](http://www.akademiaikiado.hu)

**7. E-mail** (2009. szeptember 08, kedd, 3:58 PM):

**From:** [Fehér Katalin](#)  
**To:** '[gulyas@ginprofessional.hu](mailto:gulyas@ginprofessional.hu)'  
**Sent:** Tuesday, September 08, 2009 3:58 PM  
**Subject:** RE: MODERN KÖNYVVITELTAN - ajánlat kiadásra

Tisztelt Gulyás István, ezúton értesítem, hogy **szakértői döntés alapján az Akadémiai Kiadó nem kíván élni a kézirat gondozásának jogával.**

Megértését köszönöm, a jövőbeli terveihez a legjobbakat kívánom. Üdvözlettel,

Dr. Fehér Katalin PhD  
vezető szerkesztő  
Akadémiai Kiadó Zrt.  
1117 Budapest,  
Prielle Kornélia u. 19/D  
(1) 464 8274  
[www.akademiaikiado.hu](http://www.akademiaikiado.hu)

## Applied major notation

$\cong$	Approximately equal
$\geq$	Greater or equal
$\leq$	Less or equal
$\equiv$	Less or greater or equal
$\Delta$	Small difference
$\infty$	Infinite (large or small) number or quantity
$f$	Function, mapping or rule of the assignment
$\phi$	Function, mapping or rule of the assignment
$\rightarrow$	Mapping, assignment
$\longrightarrow$	Implication
$\pm$	Positive or negative
$\neq$	Non equal
$\equiv$	Equivalent (other: same)
$\approx$	Approximately same
$\dots$	Continuation by previous
$\cup$	Union of sets
$\not\subset$	Non part of something
$\subset$	Real part of something
$\subseteq$	Part or equal of something
$\in$	Element of something
$\notin$	Non element of something
$\sum$	Sum
<b>A</b>	The set <b>A</b>
<b>S</b>	Matrix
<b>v</b> *	Row vector
<b>v</b>	Column vector
<b>1</b>	summarizing column vector (all element of it is 1)
<b>0</b>	null vector (all element of it is 0)
$\wedge$	Conjunction (logical and)
$\vee$	Disjunction (logical and/or)
$\nabla$	exclusive or (logical only or)